

# TCS-NET RELAY INTERFACE

## BMS-IFLSV2E2

- Thank you very much for purchasing this TOSHIBA TCS-NET Relay Interface.
- Please read this manual carefully beforehand for proper installation of the relay interface.

### CONTENTS

Precautions for Safety .....	1
Introduction .....	2
Before Installation .....	3
1 Installation .....	3
2 Connection of Power cables/Earth wires/Signal wires .....	4
3 Setting .....	6
4 Trial Operation Check .....	7

# Precautions for Safety

---

- Read these "Precautions for Safety" carefully before installation.
- The precautions described below include important items regarding safety. Observe them without fail.
- After the installation work, perform a trial operation to check for any problem. Follow the Owner's Manual to explain how to use and maintain the unit to the customer. Ask the customer to keep this Installation Manual together with the Owner's Manual.

## WARNING

- **Ask an authorized dealer or qualified installation professional to install or reinstall the relay interface.**  
Improper installation may result in electric shock or fire.
- **Turn off the main power supply switch or breaker before attempting any electrical work.**  
Make sure all power switches are off. Failure to do so may cause electric shock.
- **Perform installation work properly according to this Installation Manual.**  
Improper installation may result in electric shock or fire.
- **Do not modify the unit.**  
Any modification may cause a malfunction, resulting in overheating or fire.

## CAUTION

- **Perform wiring correctly in accordance with specified the current capacity.**  
Failure to do so may result in short-circuiting, overheating, or fire.
- **Connect the specified cables for the terminals securely to prevent external forces from affecting them.**  
Failure to do so may result in disconnection, overheating, or fire.

# Introduction

## Applications/Functions/Specifications

### • Applications

The TCS-NET Relay Interface is used to connect air conditioners (with TCC-LINK installed) to the air conditioner control system.

### • Functions

The TCS-NET Relay Interface converts signals between TCC-LINK and RS-485.

### • Specifications

Power supply	220 - 240 V, AC 50/60 Hz
Current	18 mA
Power consumption	2.4 W
Operating temperature/humidity	0 to 40 °C, 10 to 90% RH (no condensation)
Storage temperature	-20 to +60 °C
Chassis material	Galvanized sheet metal 0.8t (no coating)
Dimensions	66 (H) x 170 (W) x 200 (D) mm
Mass	1 kg

## External View

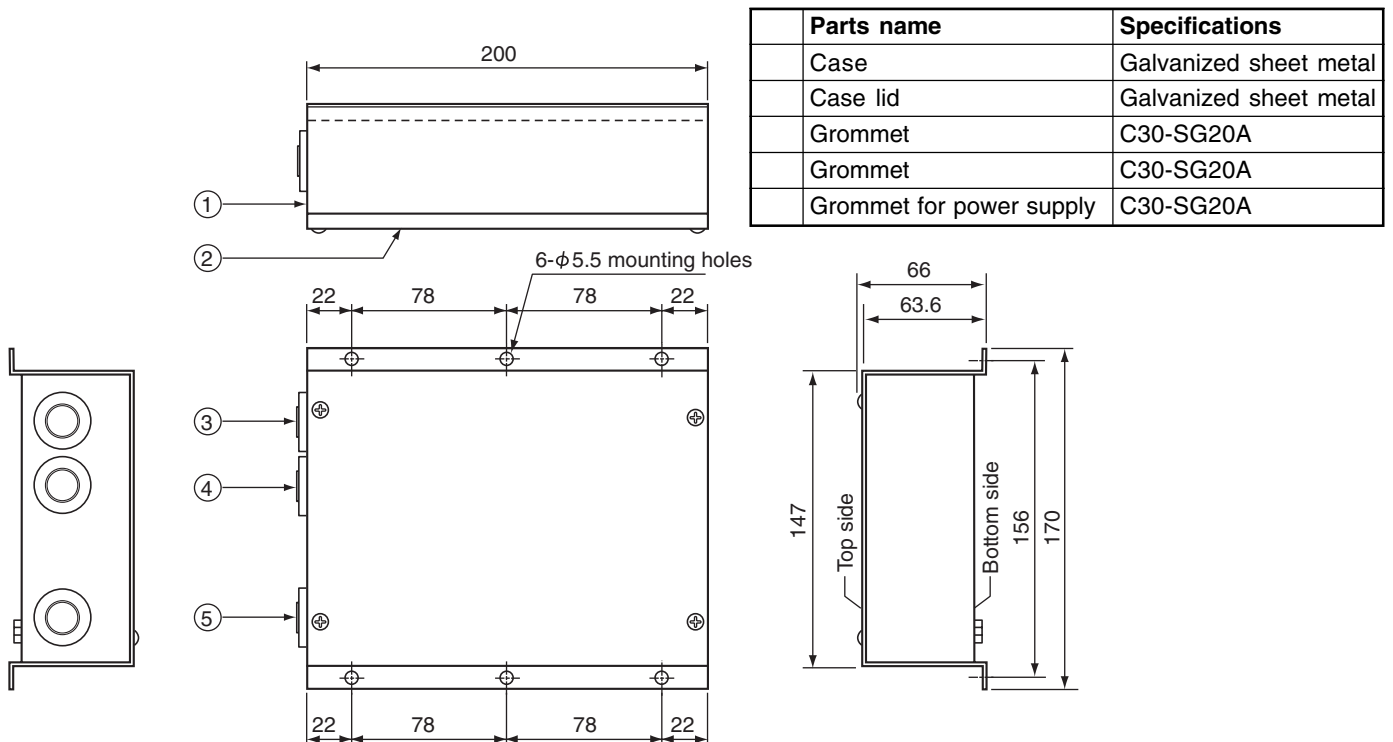

# Before Installation

Check the following package contents.

No.	Item	Quantity	Remarks
1	TCS-NET Relay Interface	1	
2	Installation Manual	1	
3	Screw	4	M4 x 12mm tapping screws

Use the following wiring materials to connect the signal lines and power lines. (Procured on site)

No.	Line	Description	
1	For TCC-LINK	Type	2-core shield wires
		Wire size	1.25 mm <sup>2</sup> , 1000m max. (total length including air conditioner area)
		Length	2.00 mm <sup>2</sup> , 2000m max.
2	For RS-485	Type	2-core shield wires
		Wire size	1.25 mm <sup>2</sup> , 500m max. (total length)
		Length	
3	For power	Type	H07 RN-F or 245IEC66
		Wire size	0.75mm <sup>2</sup> , 50 m max.

## 1 Installation

### TCS-NET Relay Interface Installation Method and Orientation

There are five installation methods for this relay interface as shown below: surface mount and wall mounts. Use the attached screws.

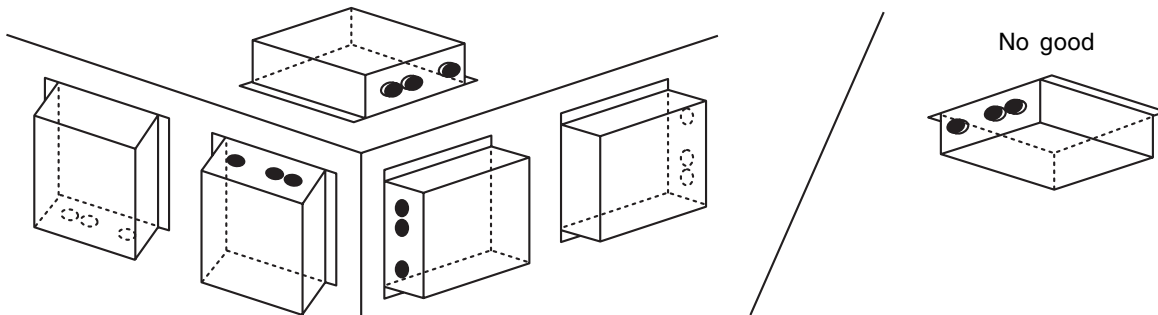

#### REQUIREMENT

**Do not install the unit in any of the following places.**

- Humid or wet place
- Dusty place
- Place exposed to direct sunlight
- Place where there is a TV set or radio within one meter
- Place exposed to rain (outdoors, under eaves, etc.)

#### Installation Space and Maintenance Space

A side space for connecting through cable inlets and an upper space for maintenance must be reserved before installation. The other sides can be adjacent to surrounding objects.

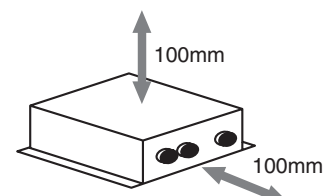

# 2 Connection of Power cables/Earth wires/ Signal wires

## CAUTION

- The RS-485 signal lines have polarity. Connect A to A, and B to B. If connected with incorrect polarity, the unit will not work.
- The TCC-LINK signal lines have no polarity.

## Power cables/Earth wires/Signal wires

Connect power cables, earth wires, and signal wires to the specified terminals on the terminal block.

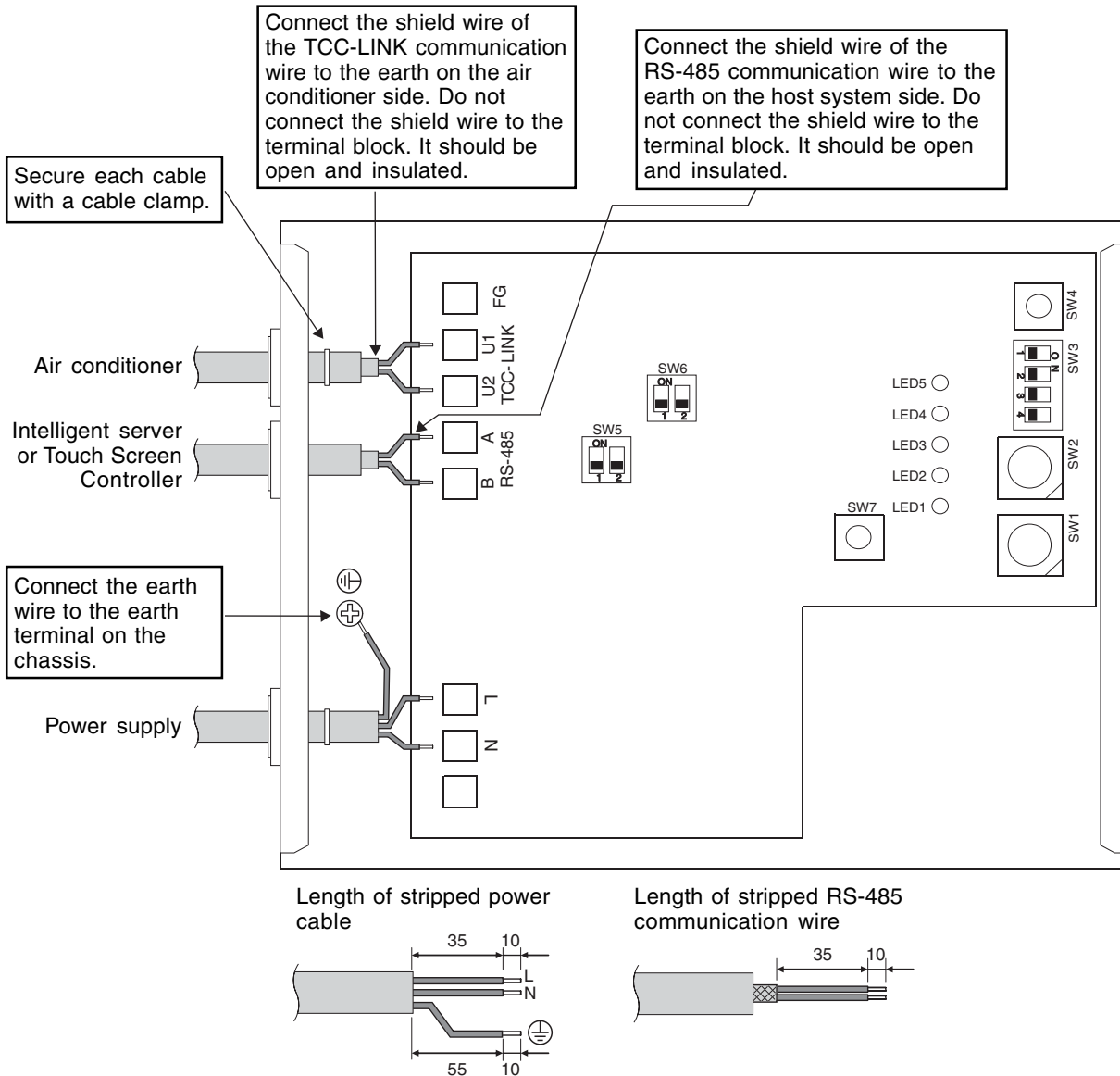

**REQUIREMENT**

**Disconnect the appliance from the main power supply.**  
 This appliance must be connected to the main power supply by a circuit breaker or switch with a contact separation of at least 3mm.

# 2 Connection of Power cables/Earth wires/ Signal wires (continued)

## Wiring Connection

The following describes a connection example when using two or more TCS-NET Relay Interface units.

### • Terminator resistor setting (See “3 SETTING” for the setting method.)

- Set the RS-485 terminator resistor to “120 ohm” for No.1 (relay interface address SW1=1) TCS-NET Relay Interface unit, and set to “open” for other units.
- Set the TCC-LINK terminator resistor to “open” as it is set on the air conditioner side.

### • Shield earthing

- The shield of RS-485 signal wires should be connected at closed end, and the terminal end should be open and insulated. The shield earth of the RS-485 signal wires should be single-point earth at the host system.  
The shield earth of the RS-485 signal wires should be single-point earth.
- The shield of TCC-LINK signal lines should be connected at the closed end, and the TCS-NET Relay Interface terminal end should be open and insulated. Earth is connected on the air conditioner side.

TOUCH SCREEN CONTROLLER

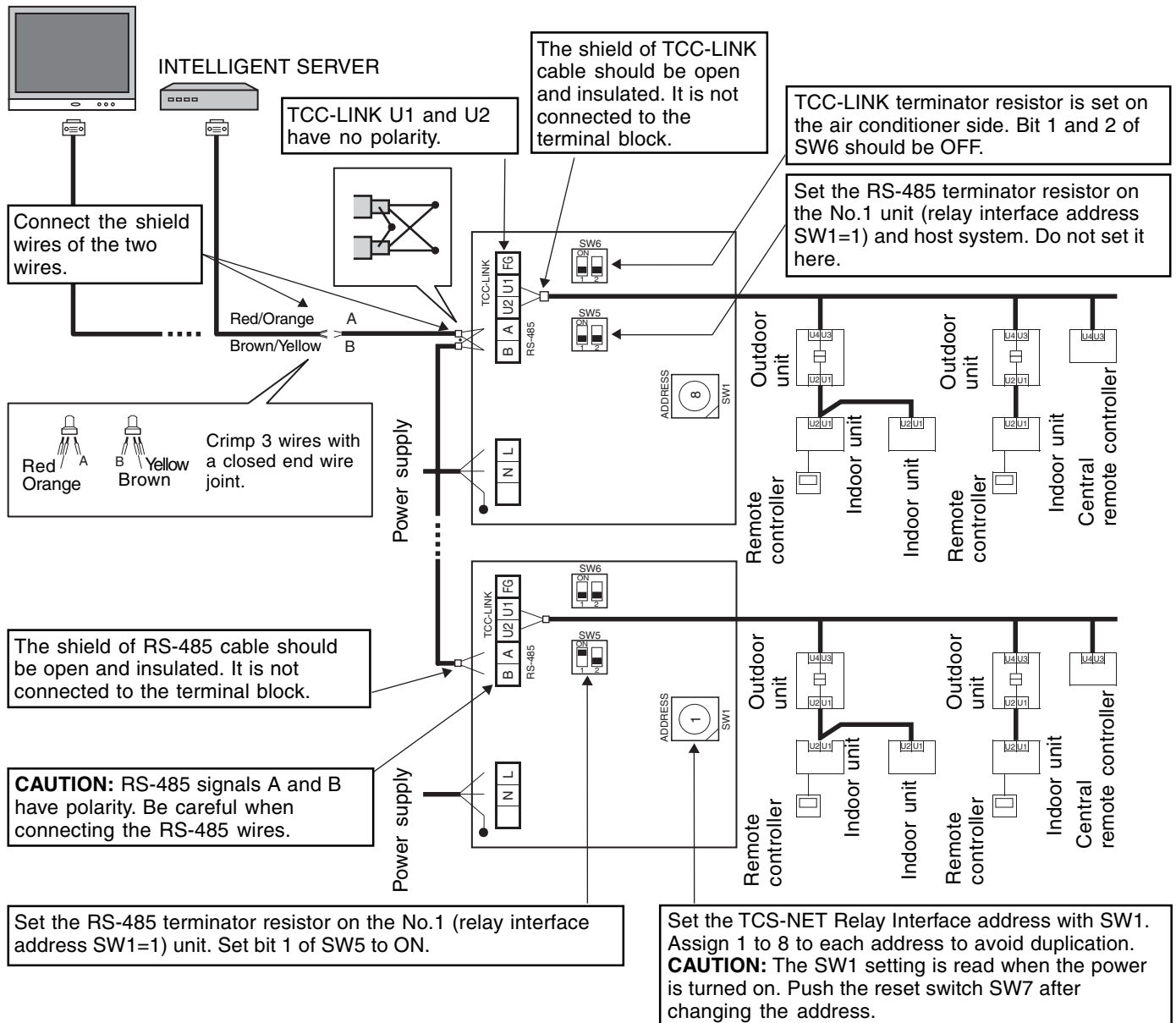

# 3 Setting

The following settings are necessary to use TCS-NET Relay Interfaces.

- **SW1** TCS-NET Relay Interface address set switch  
When two or more TCS-NET Relay Interfaces are used, set a different address for SW1 to avoid address duplication.  
Assign addresses in an ascending order.

## ⚠ CAUTION

- **Set relay interface addresses according to the air conditioner address table.**  
For the relay interface whose address SW1=1, perform terminator resistor setting.
- **When the SW1 setting has been changed, push the reset switch SW7. The new address setting is read.**

- **SW2** Test switch
- **SW3** Test switch
- **SW4** Test switch  
Not used during operation.  
Set these switches to zero (0) or “all OFF”.
- **SW5** RS-485 terminator resistor select switch  
Set “120 ohm” only when the relay interface address SW=1, and set “open” for other relay interfaces.
- **SW6** TCC-LINK terminator resistor select switch  
The TCC-LINK terminator resistor is set on the air conditioner side. Set SW6 to “open”.
- **SW7** Reset switch  
When performing an address setting with SW1, push this reset switch after the address setting to read the set value.

SW1	Relay interface address set switch	
	1-8	Relay interface address
	0, 9-F	Not used
SW2	Test switch (0 usually)	
SW3	Test switch (all OFF usually)	
SW4	Test switch	
SW5	RS-485 terminator resistor select switch	
	60 ohm	120 ohm
	120 ohm	Open
SW6	TCC-LINK terminator resistor select switch	
	100 ohm	Open
	Note: Bit 2 is not used.	
SW7	Reset switch	
LED1	Power indicator	
LED2	RS-485 communication status indicator	
LED3	TCC-LINK Communication status indicator	
LED4	TCC-LINK Communication error indicator	
LED5	Test indicator	

**REQUIREMENT**

- **RS-485 terminator resistor select switch SW5.**  
Set “120 ohm” only when the TCS-NET Relay Interface address SW=1, and set “open” for other relay interfaces.
- **The TCC-LINK terminator resistor is set on the air conditioner side. Set SW6 to “open”.**

# 4 Trial Operation Check

## Before starting trial operation

Complete the air conditioner trial operation.

Turn on the power of the TCS-NET Relay Interface after all cable connections and settings are completed. Then turn on power of the Touch Screen Controller or Intelligent Server.

## Trial operation

Check the TCC-LINK and RS-485 communication status of the TCS-NET Relay Interface by checking the blinking of the LEDs.

### ⚠ CAUTION

For the operation check of the Touch Screen Controller, refer to the Touch Screen Controller Installation Manual.

		Normal operation	Abnormal operation
LED 1	Power indicator	ON	OFF
LED 2	RS-485 communication status indicator	Blinking	OFF
LED 3	TCC-LINK Communication status indicator	Blinking	OFF
LED 4	TCC-LINK Communication error indicator	OFF	ON
LED 5	Test indicator	OFF	ON

- LED1 Power indicator  
ON: While power is on  
OFF: When power is not turned on
- LED2 RS-485 communication status indicator  
Blinking: When RS-485 communication with the host system is normal  
OFF: When RS-485 communication with the host system is disabled
- LED3 TCC-LINK Communication status indicator  
Blinking: When TCC-LINK communication with any of the air conditioners is normal  
OFF: When TCC-LINK communication with all air conditioners is disabled
- LED4 TCC-LINK Communication error indicator  
ON: While TCS-NET Relay Interface cannot send signals due to busy communication on the air conditioner side. This state is temporary. This LED turns OFF after a while and communication will restart.  
OFF: When communication on the air conditioner side is not busy
- LED5 Test indicator  
Not used in normal operation  
Displayed only in the test mode