



TOSHIBA

Leading Innovation >>>

AIR CONDITIONER (SPLIT TYPE)

Installation Manual



Branch kit 1:3

Model name:

RBC-TRP100E

Installation Manual Air conditioner (Split type)	1	English
Manuel d'installation Climatiseur (Type split)	21	Français
Installations-handbuch Klimagerät (Split-typ)	41	Deutsch
Manuale di installazione Condizionatore d'aria (Tipo split)	61	Italiano
Manual de instalación Aire acondicionado (Tipo split)	81	Español
Manual de Instalação Ar condicionado (Tipo split)	101	Português
Installatiehandleiding Airconditioner (Gesplitst type)	121	Nederlands
Εγχειρίδιο εγκατάστασης Κλιματιστικό (Τύπου Split)	141	Ελληνικά
Руководство по установке Кондиционер воздуха (сплит-система)	161	Русский
Montaj Kılavuzu Klima (Split tip)	181	Türkçe

Please read this Installation Manual carefully before installing the Air Conditioner.

- This Manual describes the installation method of the indoor unit.
- For installation of the outdoor unit, follow the Installation Manual attached to the outdoor unit.

ADOPTION OF NEW REFRIGERANT

This Air Conditioner is a new type which adopts a new refrigerant HFC (R410A) instead of the conventional refrigerant R22 in order to prevent destruction of the ozone layer.

Contents

1	PRECAUTIONS FOR SAFETY	2
2	COMPONENT	5
3	REFRIGERANT PIPING	6
4	WIRING	11
5	PIPING HEAT INSULATION	20
6	TEST RUN	20
7	DELIVERY TO CUSTOMER	20

1 PRECAUTIONS FOR SAFETY

The three indoor units of TOSHIBA simultaneous triple packaged air conditioning system are the same units. Set and install the main and sub units taking the installation site into consideration. (Be certain to use the new refrigerant R410A in the indoor units.) The indoor unit connected to the remote controller will be the main unit.

- Ensure that all Local, National and International regulations are satisfied.
- Read indoor, outdoor installation manual and this manual carefully before Installation.
- The precautions described below include the important items regarding safety. Observe them without fail.
- After the installation work, perform a trial operation to check for any problem. Follow the Owner's Manual to explain how to use and maintain the unit to the customer.
- Turn off the main power supply switch (or breaker) before the unit maintenance.
- Ask the customer to keep the Installation Manual together with the Owner's Manual.

WARNING

EN

- **Ask an authorized dealer or qualified installation professional to install/maintain the air conditioner.**
Inappropriate installation may result in water leakage, electric shock or fire.
- **Turn off the main power supply switch or breaker before attempting any electrical work.**
Make sure all power switches are off. Failure to do so may cause electric shock.
- **Connect the connecting cable correctly.**
If the connecting cable is connected in a wrong way, electric parts may be damaged.
- **When moving the air conditioner for the installation into another place, be very careful not to enter any gaseous matter other than the specified refrigerant into the refrigeration cycle.**
If air or any other gas is mixed in the refrigerant, the gas pressure in the refrigeration cycle becomes abnormally high and it resultantly causes pipe burst and injuries on persons.
- **Do not modify this unit by removing any of the safety guards or by by-passing any of the safety interlock switches.**
- **Exposure of unit to water or other moisture before installation may cause a short-circuit of electrical parts.**
Do not store it in a wet basement or expose to rain or water.
- **After unpacking the units, examine them carefully if there are possible damage.**
- **Do not install in a place that might increase the vibration of the unit.**
- **To avoid personal injury (with sharp edges), be careful when handling parts.**
- **Perform installation work properly according to the Installation Manual.**
Inappropriate installation may result in water leakage, electric shock or fire.
- **When the air conditioner is installed in a small room, provide appropriate measures to ensure that the concentration of refrigerant leakage occur in the room does not exceed the critical level.**

-
- **Install the air conditioner securely in a location where the base can sustain the weight adequately.**
 - **Perform the specified installation work to guard against an earthquake.**
If the air conditioner is not installed appropriately, accidents may occur due to the falling unit.
 - **If refrigerant gas has leaked during the installation work, ventilate the room immediately.**
If the leaked refrigerant gas comes in contact with fire, noxious gas may generate.
 - **After the installation work, confirm that refrigerant gas does not leak.**
If refrigerant gas leaks into the room and flows near a fire source, such as a cooking range, noxious gas might generate.
 - **Electrical work must be performed by a qualified electrician in accordance with the Installation Manual. Make sure the air conditioner uses an exclusive power supply.**
An insufficient power supply capacity or inappropriate installation may cause fire.
 - **Use the specified cables for wiring connect the terminals securely fix. To prevent external forces applied to the terminals from affecting the terminals.**
 - **Conform to the regulations of the local electric company when wiring the power supply.**
Inappropriate grounding may cause electric shock.
 - **Do not install the air conditioner in a location subject to a risk of exposure to a combustible gas.**
If a combustible gas leaks, and stays around the unit, a fire may occur.
-

 **CAUTION**

New Refrigerant Air conditioner Installation

- **THIS AIR CONDITIONER ADOPTS THE NEW HFC REFRIGERANT (R410A) WHICH DOES NOT DESTROY OZONE LAYER.**
- The characteristics of R410A refrigerant are; easy to absorb water, oxidizing membrane or oil, and its pressure is approx. 1.6 times higher than that of refrigerant R22. Accompanied with the new refrigerant, refrigerating oil has also been changed. Therefore, during installation work, be sure that water, dust, former refrigerant, or refrigerating oil does not enter the refrigerating cycle.
- To prevent charging an incorrect refrigerant and refrigerating oil, the sizes of connecting sections of charging port of the main unit and installation tools are changed from those for the conventional refrigerant.
- Accordingly the exclusive tools are required for the new refrigerant. (R410A)
- For connecting pipes, use new and clean piping designed for R410A, and please care so that water or dust does not enter. Moreover, do not use the existing piping because there are problems with pressure-resistance force and impurity in it.
- The three indoor units of TOSHIBA simultaneous triple packaged air conditioning system are the same units.
- Set and install the main and sub units taking the installation site into consideration. (Be certain to use the new refrigerant R410A in the indoor units.)
The indoor unit connected to the remote controller will be the main unit.

EN**Wiring**

- **TO DISCONNECT THE APPLIANCE FROM MAIN POWER SUPPLY.**
- This appliance must be connected to the main supply by means of a switch with a contact separation of at least 3mm.
- The remote controller cannot be connected to all the three indoor units (main and sub units).
Connect it only to the indoor unit that will become the main indoor unit (Unit A).
Connecting the remote controller to the sub indoor unit will cause malfunction.

Refrigerant Piping (Branch piping system is used for refrigerant piping)

- Compared with R22, pressure of R410A is about 1.6 times. Unless the piping is installed correctly, gas leak may be caused during operation such as pressure boosting. Conduct a leak test of the pipe connecting parts correctly.
 - In case the actual length of the piping exceeds the standard piping length, accurately add the refrigerant referring to Additional Refrigerant Amount.
 - Heat insulation materials for the branch pipes are not supplied as accessories. Provide heat insulation correctly using fitting covers or other materials sold on the market. For further information, read Refrigerant Piping and Piping heat Instruction on this manual. Improper heat insulation work will result in a failure and a claim.
-

2 COMPONENT

The following parts are supplied as accessories of the branch pipes. Check them when opening the carton box.

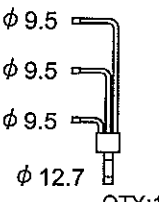
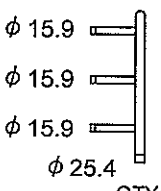
Distributor		Part name		Quantity
Liquid side	Gas side	Different-size joint		
		Liquid pipe	Ø12.7 → Ø9.5	1
			Ø9.5 → Ø6.4	3
		Gas pipe	Ø25.4 → Ø15.9	1
Ø15.9 → Ø12.7	3			
		Branch pipe heat insulator		2
		Installation Manual		1

3 REFRIGERANT PIPING

■ Tolerance of pipe length and Height difference

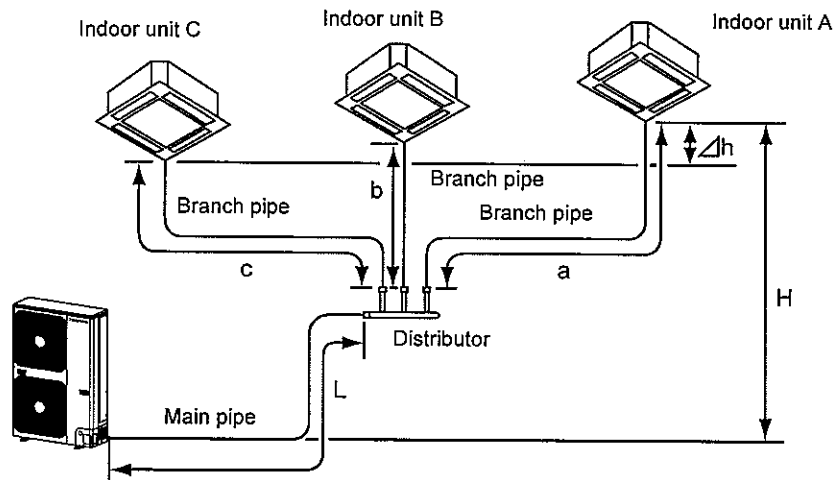

EN

Refrigerant pipe specifications	Pipe length (one way)	Total length ($L + a, L + b, L + c$)		50 m
		Branch pipe length (a, b, c)		15 m
		Maximum difference between indoor units ($ a - b , b - c , c - a $)		10 m
	Height difference	Between indoor units (Δh)		0.5 m
		Between indoor unit and outdoor unit	When outdoor unit is higher (H)	30 m
			When outdoor unit is lower (H)	30 m
Number of bent portions				10 or less

⚠ CAUTION

When planning a layout for Units A, B and C, comply with the following:

1. The lengths after branching ("a" and "b", "b" and "c", "a" and "c") should be equal if feasible. Install Units A, B and C so that the difference of the branching lengths becomes less than 10m if the lengths cannot be equal due to the branch pipe position.
2. Install Units A, B and C on the same level. If Units A, B and C cannot be installed on the same level, the difference in level should be limited to 0.5 m or less.
3. Be certain to install Units A and B and C in the same room. Units A, B and C cannot be operated independently each other.

■ Piping materials and sizes

Use copper tube of Copper and copper alloy seamless pipes and tubes, with 40 mg/10 m or less in the amount of oil stuck on inner walls of pipe and 0.8 mm in pipe wall thickness for diameters 6.4, 9.5 and 12.7 mm and 1.0 mm, for diameter 15.9 mm. Never use pipes of thin wall thickness such as 0.7 mm.

<Between outdoor unit and distributor>

[Unit: mm]

Outdoor unit		
Main pipe	Gas side	Ø15.9 (1.0)
	Liquid side	Ø9.5 (0.8)

* (): Pipe wall thickness

<Between distributor and indoor unit>

[Unit: mm]

Indoor unit		SM56 type
Branch pipe	Gas side	Ø12.7 (0.8)
	Liquid side	Ø6.4 (0.8)

* (): Pipe wall thickness

■ Distributor

Now the refrigerant pipe is installed using distributor supplied as accessories.

- Bend and adjust the refrigerant piping so that the distributor and pipe after branching become horizontal.
- Fix the distributor onto a wall in a ceiling or onto a column.
- Provide a straight pipe longer than 500 mm in length as the main piping of the branches.

<How to install distributor>

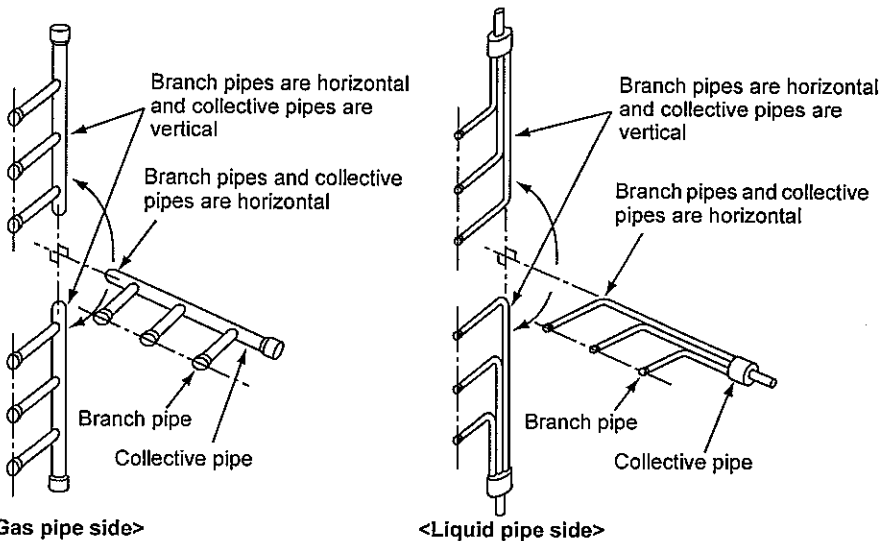

EN

<Restrictions in length of the straight area of the branch pipe (main pipe side)>

Provide a straight area of 500 mm or more on the main pipe side of the branch pipe (for both gas pipe and liquid pipe sides).

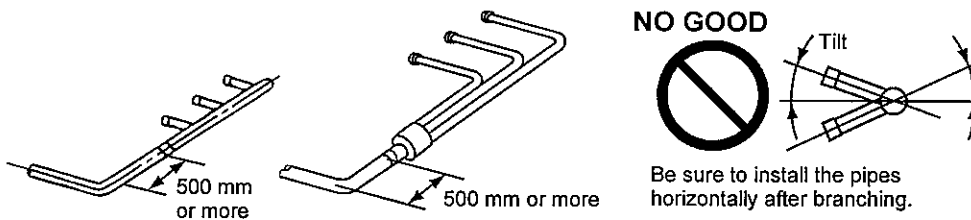

■ Air Purging

For the complete information, read the installation manual for outdoor units of air conditioner.

■ Additional Refrigerant Amount

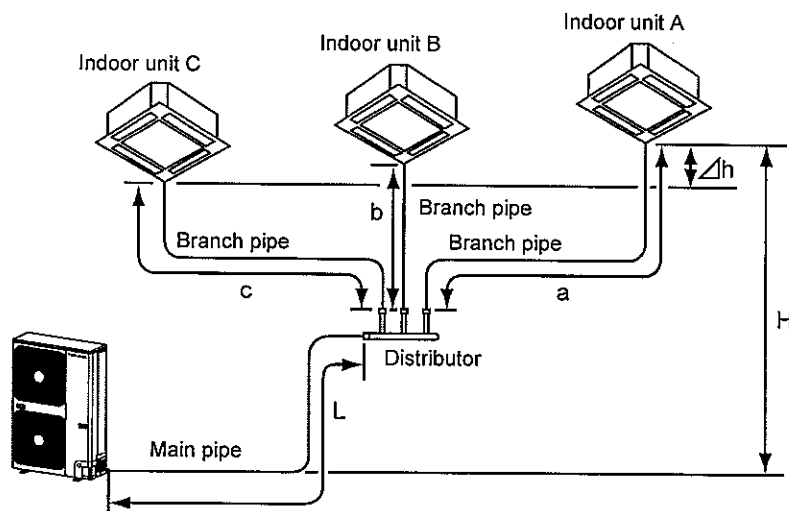

<Formula for Calculating Additional Refrigerant Amount>

Do not remove the refrigerant even if the additional refrigerant amount becomes minus result as a result of calculations by the following formula and operate the air conditioner as it is.

Additional refrigerant amount (kg) = Main piping additional refrigerant amount (kg) + Branch piping additional refrigerant amount (kg) = $\{\alpha \times (L - 28)\} + \{\gamma \times (a + b + c - 6)\}$

- α: Additional refrigerant amount per meter of actual main piping length (kg)
- γ: Additional refrigerant amount per meter of actual branch piping length (kg)
- L: Actual length of main piping (m)
- a, b, c: Actual length of branch piping (m)

	Connecting pipe diameter				Additional refrigerant amount per Meter (kg/m)		
	L	a	b	c	α	β	γ
DI 6HP	φ9.5	φ6.4	φ6.4	φ6.4	0.04	-	0.02

⚠ CAUTION

1. Be certain to write the additional refrigerant amount, pipe length (actual length), head and other specification on the nameplate put on the outdoor unit for recording.
2. Seal the correct amount of additional refrigerant in the system.

■ Gas Leak Test

- Use a leak detector manufactured specially for the HFC refrigerant (R410A, R134a, etc.) when testing R410A.
The sensitivity of leak detectors for previous HCFC refrigerants (such as R22) lowers to about 1/40 when used with HFC refrigerants and these detectors cannot be used.

A small black square containing the white text "EN".

4 WIRING

1. **Using the specified cables, ensure to connect the wires, and fix wires securely so that the external tension to the cables do not affect the connecting part of the terminals.**
Incomplete connection or fixation may cause a fire, etc.
Be certain to install wires by connecting them to terminals of the same numbers according to the following wiring diagram.
2. **Be sure to connect earth wire. (Grounding work)**
Do not connect the earths wire to gas pipe, city water pipe, lightning rod, or the earth wire of telephone.
Incomplete grounding causes an electrical shock.
3. **For electric work, strictly follow the Local Regulation in each country, Indoor, outdoor, and this Installation Manual, and use an exclusive circuit.**
Capacity shortage of power circuit or incomplete installation may cause an electrical shock or a fire.

■ Internal And External Connection Wiring

1. Install wires from the outdoor unit to the main unit as in usual wiring.
(Wires (1), (2), (3) and ground wire.)
2. Install wires (1), (2) and ground wire only when installing connection wires from the header unit to the follower unit.

■ Remote Controller wiring

1. Installing connection shield wires (MVVS 0.5 to 2.0 mm²) from the header unit to the follower unit to conform to EMC standard.
2. Install shield wires between the header unit and follower unit. The shield wires of the remote controller have no polarities.
The remote controller circuits are low voltage circuits. These circuits must not be made to directly contact internal and external wires or contained in the same conduit tubes that house internal and external wires.
(Otherwise malfunction will be caused by noise)

■ Wiring Diagram

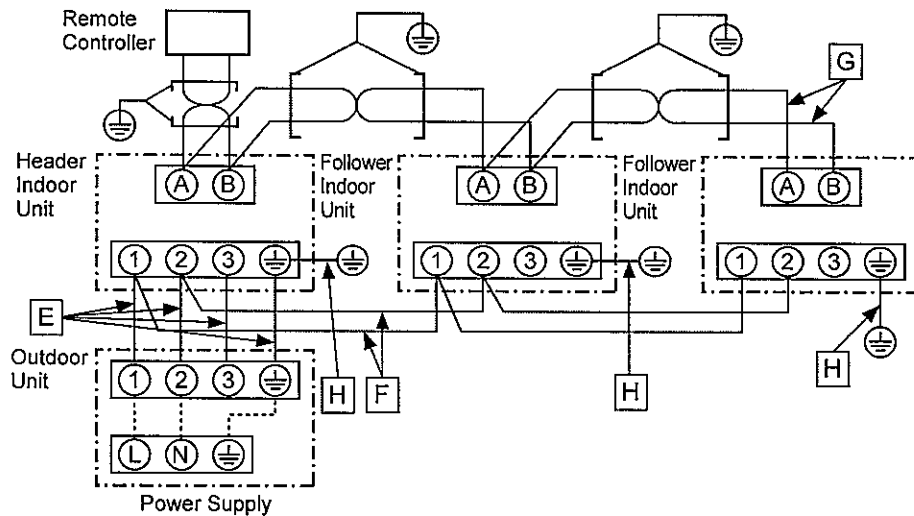

EN

REQUIREMENT

- The remote controller wiring has no polarity. Connections to terminals A and B of an indoor unit may be replaced with each other.
- The remote controller wires and 220-240VAC wire must not be in direct contact or in the same conduit pipe. (Doing so may cause a malfunction of the control system due to noise.)

■ Wiring Specification

Specification of Wires Between Units and Numbers of Wires.

Outdoor unit - indoor unit (header unit) <input type="checkbox"/>	No. of wires	4 (Include ground wire)
	Wire diameter	H07RN-F or 60245IEC66 1.5 mm ² or more
Indoor unit - indoor unit (main unit) (follower unit) <input type="checkbox"/>	No. of wires	2
	Wire diameter	H07RN-F or 60245IEC66 1.5 mm ² or more
Remote controller wiring <input type="checkbox"/>	No. of wires	2 (Shield wire)
	Wire diameter	Between 0.5 mm ² and 2 mm ² (up to 200 m)
Grounding wire of indoor sub unit <input type="checkbox"/>		H07RN-F or 60245IEC66 1.5 mm ² or more

Procure necessary parts and perform all connection work locally.

⚠ WARNING

For simultaneous triple systems, perform the following to conform to EMC standards.

1. Be sure to use shield wire for remote controller wiring.
2. Connect earth wire independently to each indoor unit.
3. Attach the ferrite core (white) supplied with the outdoor unit to indoor/outdoor connecting wires.
 - Pass indoor/outdoor connecting wires ① and ② through the supplied ferrite core and wind them making a single turn, and then connect them to the terminals of the outdoor unit. Connect the indoor/outdoor connecting wire ③ and the earth wire directly to the outdoor unit terminals.
4. Attach the clamp filter (gray) supplied with the outdoor unit to the outdoor fan motor lead wire.
 - Attach the supplied clamp filter securely to the fan motor lead wire (lower) in the electric parts box of the outdoor unit.

- For how to install the indoor unit, refer to the Installation Manual supplied with the indoor unit.

<1. Attaching the ferrite core>

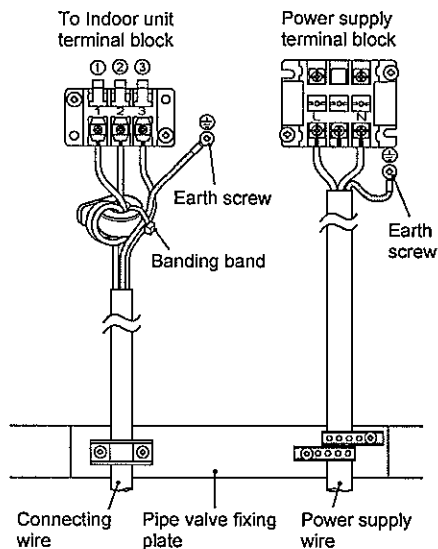

- * Clamp the indoor/outdoor connecting wire ③ and the earth wire together with the ferrite core with the supplied banding band.

Stripping length power cord and connecting wire

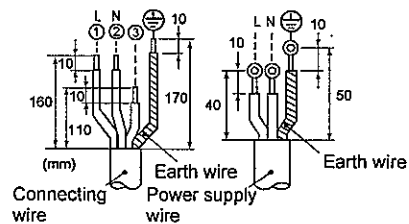

<2. Attaching the clamp filter>

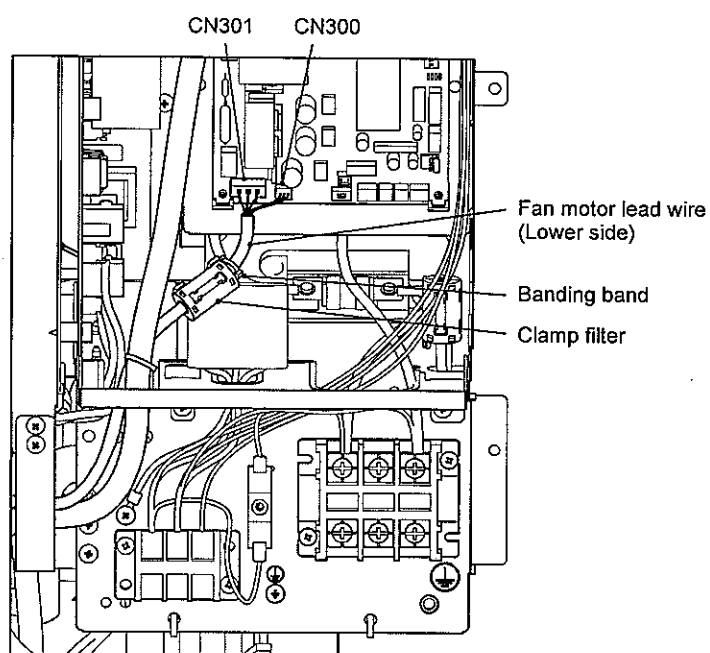

EN

Attach the clamp filter supplied with the outdoor unit to the lower outdoor fan motor lead wire.

- Make sure that the claw of the clamp filter is securely locked.
- Pass the banding band supplied with the outdoor unit through the upper hole of the clamp filter to clamp it together with the fan motor lead wire.
- The fan motor lead wires are connected to the connectors CN301 and CN300 on the P.C. board of the outdoor unit.

NOTE

When using the equipment at the first time, it will take a lot of time that the remote controller accepts an operation after power was on. However, it is not a trouble.

Automatic address

While automatic addressing, the operation can not be performed on the remote controller.

- For automatic addressing, Max. 10 minutes (generally, approx. 5 minutes) are required.

When power will be turned on after finish of automatic addressing;

- It will require Max. 10 minutes (generally, approx. 3 minutes) that outdoor unit starts operation after power was on.

■ Indoor Unit operation when connected to multiple unit

Simultaneous triple system

A combination with an outdoor unit allows simultaneous ON/OFF operation of three indoor units for the triple system.

▼ Triple system

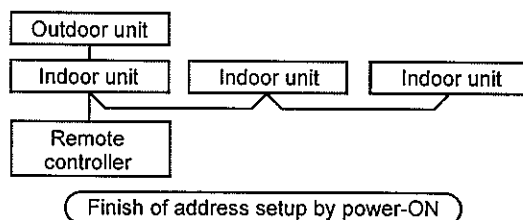

- For wiring procedure and wiring method, follow to the "Electric wiring" in this manual.
- When the power supply has been turned on, the automatic address setup starts and which indicates that address is being set up flashes on the display part.
During setup of automatic address, the remote controller operation is not accepted.

Required time up to the finish of automatic addressing is approx. 5 minutes.

In case of group control for system of multiple units

One remote controller can control maximum 8 indoor units as a group.

▼ In case of group control in single system

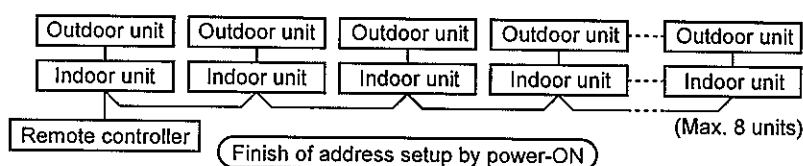

- For wiring procedure and wiring method of the individual line (Identical refrigerant line) system, follow to "Electric wiring".
- Wiring between lines is performed in the following procedure. Connect the terminal block (A/B) of the indoor unit connected with a remote controller to the terminal blocks (A/B) of the indoor units by wiring the inter-unit wire of the remote controller.
- When the power supply has been turned on, the automatic address setup starts and which indicates that address is being set up flashes on the display part. During automatic address setup, the remote controller operation is not accepted.

Required time up to the finish of automatic addressing is approx. 5 minutes.

EN

NOTE

In some cases, it is necessary to change the address manually after setup of the automatic address according to the system configuration of the group control.

- A complex system in which a single system, twin system, and triple system are controlled by one remote controller as a group requires address setup change.

(Example) Group control for complex system

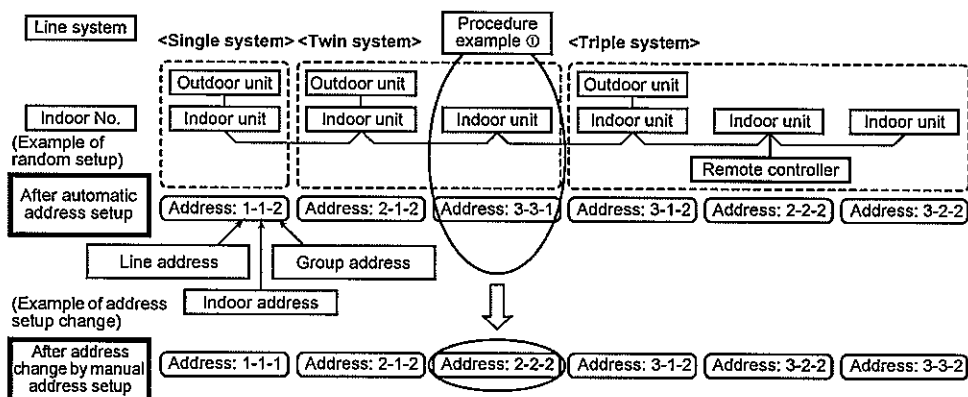

The above address is set by the automatic address setup when the power is turned on. However, line addresses and indoor addresses are set randomly. For this reason, change the setting to match line addresses with indoor addresses.

Procedure example ①

Manual address setup procedure

While the operation stops, change the setup.
(Be sure to stop the operation of the unit.)

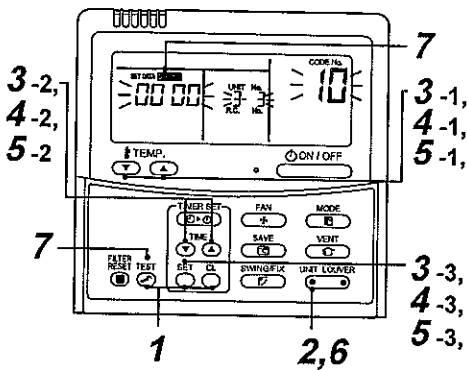

Procedure 1

Push simultaneously **SET** + **CL** + **TEST** buttons for 4 seconds or more. After a while, the display part flashes as shown below. Check the displayed CODE No. is [10].

- When the CODE No. is other than [10], push **TEST** button to erase the display and repeat procedure from the first step. (After pushing **TEST** button, operation of the remote controller is not accepted for approx. 1 minute.) (For a group control, No. of the firstly displayed indoor unit becomes the header unit.)

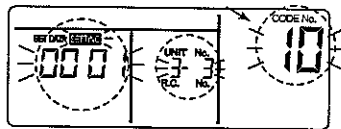

(* Display changes according to the model No. of indoor unit.)

Procedure 2

Every pushing **UNIT LOUVER** button, the indoor unit No. in the group control is displayed in order. Select the indoor unit of which setup is changed.

At this time, the position of the indoor unit of which setup is changed can be confirmed because fan and louver of the selected indoor unit operate.

Procedure 3

1. Using temp. setup **▼** / **▲** buttons, specify CODE No. [12]. (CODE No. [12]: Line address)
 2. Using timer time **▼** / **▲** buttons, change the line address from [3] to [2].
 3. Push **SET** button.
At this time, the setup finishes when the display changes from flashing to lighting.
- Indoor unit No. before setup change is displayed.

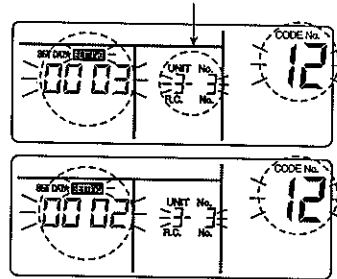

Procedure 4

1. Using temp. setup **▼** / **▲** buttons, specify CODE No. [13]. (CODE No. [13]: Indoor address)
2. Using timer time **▼** / **▲** buttons, change the indoor address from [3] to [2].
3. Push **SET** button.
At this time, the setup finishes when the display changes from flashing to lighting.

Indoor unit No. before setup change is displayed.

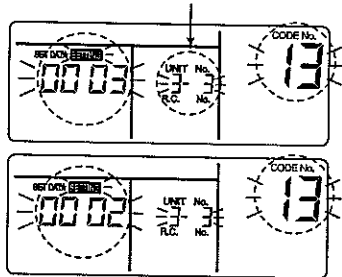

Address change check Before change: [3-3-1] → After change: [2-2-2]

Pushing button clears the contents of which setup was changed.

Indoor unit No. before setup change is displayed.

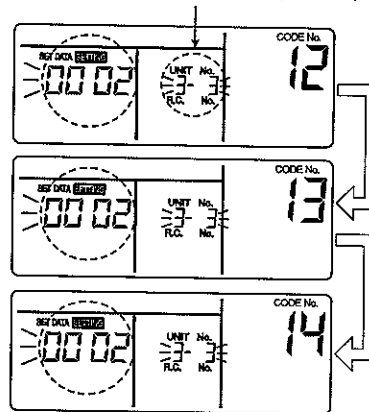

EN

Procedure 5

- Using temp. setup / buttons, specify CODE No. [14]. (CODE No. [14]: Group address)
- Using timer time / buttons, change the setup data from [0001] to [0002]. (Setup data [Header unit: 0001] [Follower unit: 0002])
- Push button.
At this time, the setup finishes when the display changes from flashing to lighting.

Indoor unit No. before setup change is displayed.

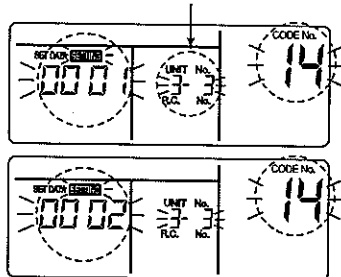

Procedure 6

If there is other indoor unit to be changed, repeat procedure 2 to 5 to change the setup.

When the above setup has finished, push to select the indoor unit No. before change of setup, specify CODE No. [12], [13], [14] in order with temp. setup / buttons, and then check the changed contents.

Procedure 7

After check of the changed contents, push button. (Setup is determined.) When pushing button, the display disappears and the status becomes the usual stop status. (When pushing button the operation from the remote controller is not accepted for approx. 1 minute.)

* If the operation from the remote controller is not accepted even 1 minute or more passed after pushing button, it is considered that the address setup is incorrect. In this case, the automatic address must be again set up.

Therefore repeat procedure of the setup change from the Procedure 1.

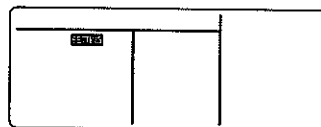

To recognize the position of the corresponding indoor unit though the indoor unit No. is known

Check the position during operation stop.
(Be sure to stop operation of the unit.)

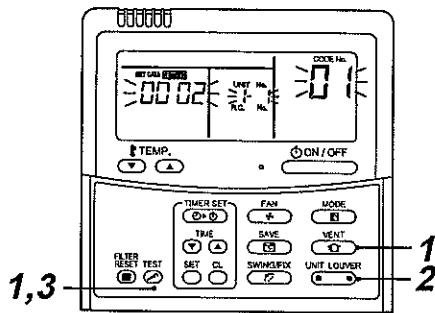

Procedure 1

Push simultaneously + buttons for 4 seconds or more.

After a while, the display part flashes and the display appears as shown below.

At this time, the position can be checked because fan and louver of the indoor unit operate.

- For the group control, the indoor unit No. is displayed as [ALL] and fans and louvers of all the indoor units in the group control operate.

Check the displayed CODE No. is [01].

- When the CODE No. is other than [01], push button to erase the display and repeat procedure from the first step.
(After pushing button, operation of the remote controller is not accepted for approx. 1 minute.)

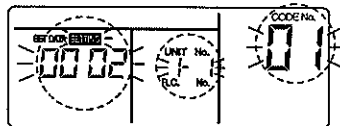

(* Display changes according to the model No. of indoor unit.)

Procedure 2

In the group control, every pushing button, the indoor unit No. in the group control is displayed in order.

At this time, the position of the indoor unit can be confirmed because only fan and louver of the selected indoor unit operate.
(For a group control, No. of the firstly displayed indoor unit becomes the header unit.)

Procedure 3

After confirmation, push button to return the mode to the usual mode.

When pushing button, the display disappears and the status becomes the usual stop status.

(When pushing button the operation from the remote controller is not accepted for approx. 1 minute.)

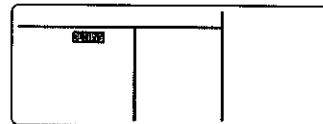

5 PIPING HEAT INSULATION

Heat insulation was produced locally.

Be certain to heat insulate the piping both on the liquid and gas sides.

- Use heat insulating materials for piping higher than 120 degree in heat resistance.
Example: EPT - Ethylene, propylene, terpolymer
- Heat insulate the branch pipe sections using fitting covers (for tees) more than 10mm in thickness or processing heat insulation materials as follows.
(Heat insulation materials for the branch pipes are not supplied as accessories.)
- Seal the branch pipe sections tightly without producing gaps

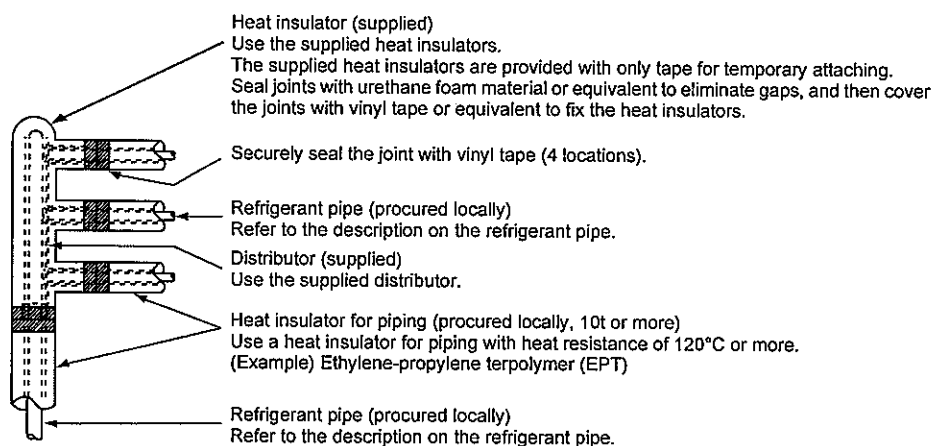

EN

6 TEST RUN

Be certain to conduct a test run in accordance with the procedures contained in the operating and installation manual supplied with the indoor units.

7 DELIVERY TO CUSTOMER

- Make certain to hand over the instruction manual supplied with the indoor units to the customer.
- Deliver the system after thoroughly explaining the contents of the instruction manual. It is important to explain to the customer in details about simultaneously starting and stopping the three indoor units by operating one remote controller switch.

EH99862001