

TOSHIBA

**OWNER'S MANUAL
MANUEL DU PROPRIETAIRE
BETRIEBSANLEITUNG
MANUALE DEL PROPRIETARIO
MANUAL DEL PROPIETARIO
ΟΔΗΓΙΕΣ ΧΡΗΣΗΣ
MANUAL DO UTILIZADOR
РУКОВОДСТВО ПОЛЬЗОВАТЕЛЯ
BRUKSANVISNING**

Not accessible to the general public
Vente interdite au grand public
Kein öffentlicher Zugang
Non accessibile a clienti generici
No destinado al público en general
Μη προσβάσιμο από το γενικό κοινό
Não acessível ao público em geral
Ограничено для доступа широкой общественности
Inte tillgänglig för allmänheten

**AIR CONDITIONER (SPLIT TYPE)
CLIMATISEUR (TYPE SPLIT)
KLIMAGERÄT (SPLIT-TYP)
CONDIZIONATORE D'ARIA (TIPO SPLIT)
AIRE ACONDICIONADO (TIPO SPLIT)
ΚΛΙΜΑΤΙΣΤΙΚΟ (ΔΙΑΙΡΟΥΜΕΝΟΥ ΤΥΠΟΥ)
AR CONDICIONADO (TIPO SPLIT)
ΚΟΝΔΙЦИОНЕР (СОСТАВНОЙ)
LUFTKONDITIONERINGSAPPARAT (SPLIT TYP)**

**<4-Way Air Discharge Cassette Type>
<Type cassette à 4 voies de soufflage>
<4-Wege-Belüftungskassette>
<Tipo a cassetta con scarico d'aria a 4 vie>
<Modelo de casete de distribución de aire de 4 vías>
<Εκροή αέρα 4-Διευθύνσεων Τύπου Κασέτας>
<Descarga de ar tipo casete de 4 vías>
<4-направленная кассета выпуска воздуха>
<Apparat med 4-vägars luftutsläpp>**

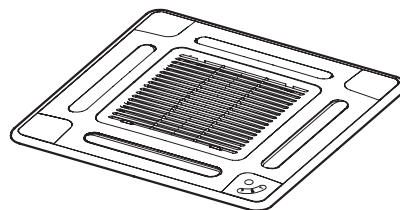

Indoor Unit

Unité intérieure/Raumeinheit/Unità interna/Unidad interior

Εσωτερική Μονάδα/Unidade interior/Внутренний блок/Inomhusenhet

Heat Pump Model
Modèle à thermopompe
Geräte mit Heizung
Modello con pompa di riscaldamento
Modelo con bomba de calor
Μοντέλο με Αντλία Θερμότητας
Modelo de bomba térmica
Модель теплового насоса
Värmepumpsmodell

Cooling Only Model
Modèle à froid seul
Geräte nur zur Kühlung
Modello solo per raffreddamento
Modelo de refrigeración únicamente
Μοντέλο Ψύξης αποκλειστικά
Modelo Apenas para Refrigeração
Модель только с охлаждением
Modell endast för avkyllning

**RAS-M10SMUV-E
RAS-M13SMUV-E
RAS-M16SMUV-E**

**RAS-M10SMUCV-E RB-B11MC(W)E
RAS-M13SMUCV-E
RAS-M16SMUCV-E**

ADOPTION OF NEW REFRIGERANT

This Air Conditioner is a new type which adopts the new refrigerant HFC (R410A) instead of the conventional refrigerant R22. R410A is an ozone friendly refrigerant.

Thank you very much for purchasing TOSHIBA Air Conditioner. Please read this owner's manual carefully before using your Air Conditioner.

- Be sure to obtain the "Owner's manual" and "Installation manual" from the installer (or dealer).

Request to the installer or dealer

- To clearly explain the contents of the Owner's manual prior to hand over.

UTILISATION DU NOUVEAU REFRIGERANT

Ce nouveau type de climatiseur utilise le nouveau réfrigérant HFC (R410A) au lieu du traditionnel R22.

Le R410A est un réfrigérant qui respecte la couche d'ozone.

Nous vous remercions d'avoir choisi un climatiseur TOSHIBA. Veuillez lire attentivement ce Manuel du propriétaire avant d'utiliser votre climatiseur.

- Assurez-vous que le monteur (ou le revendeur) vous remette le " Manuel du propriétaire " et le " Manuel d'installation ".

Demandez au monteur ou au revendeur

- d'expliquer clairement le contenu du Manuel du propriétaire avant de vous remettre.

EINFÜHRUNG EINES NEUEN KÜHLMITTELS

Dies ist ein neuartiges Klimagerät. Anstatt des herkömmlichen Kältemittels R22 verwendet es das neue HFC Kältemittel R410A. R410A schont die Ozonschicht.

Wir danken Ihnen, dass Sie sich für ein TOSHIBA Klimagerät entschieden haben. Bitte lesen Sie, bevor Sie Ihr Klimagerät benutzen, diese Betriebsanleitung sorgfältig.

- Lassen Sie sich die "Bedienungsanleitung" und das "Installations-Handbuch" unbedingt vom Installateur oder vom Lieferanten aushändigen.

Eine Bitte an den Installateur oder Lieferanten:

- Bitte erklären Sie dem Käufer den Inhalt der Bedienungsanleitung und händigen sie ihm aus.

ADOZIONE DI UN NUOVO REFRIGERANTE

Questo condizionatore d'aria è di tipo nuovo e impiega il nuovo refrigerante HFC (R410A) invece del R22, tradizionalmente usato. R410A è un refrigerante ecologicamente rispettoso dello strato d'ozono.

Grazie di aver acquistato un condizionatore d'aria TOSHIBA.

Prima di cominciare ad usare il condizionatore d'aria, leggere attentamente il Manuale del proprietario.

- Farsi consegnare dall'installatore (o dal rivenditore) sia il "Manuale d'installazione" che il "Manuale del proprietario".

Richiedere all'installatore o al rivenditore

- Di spiegare chiaramente le istruzioni contenute nel Manuale del proprietario, prima di consegnarlo.

ADOPCIÓN DE NUEVO REFRIGERANTE

Este acondicionador de aire es un tipo Nuevo que adopta el refrigerante nuevo HFC (R410A) en vez del refrigerante convencional R22. El R410A es un refrigerante que no daña la capa de ozono.

Muchas gracias por haber adquirido este acondicionador de aire TOSHIBA.

Lea atentamente este manual del usuario antes de utilizar el aparato de aire acondicionado.

- Asegúrese de que el instalador (o distribuidor) le proporcione el "Manual del usuario" y el "Manual de instalación".

Solicítelo al instalador o distribuidor

- Para explicar con claridad el contenido del Manual del usuario, antes de efectuar la entrega.

ΥΙΟΘΕΤΗΣΗ ΝΕΟΥ ΨΥΚΤΙΚΟΥ

Το παρόν Κλιματιστικό είναι νέου τύπου και υιοθετεί το νέο ψυκτικό HFC (R410A) αντί για το συμβατικό ψυκτικό R22.

Το R410A είναι ένα ψυκτικό φιλικό ως προς το όζον.

Σας ευχαριστούμε πολύ που προτιμήσατε για την αγορά σας ένα Κλιματιστικό TOSHIBA.

Παρακαλούμε διαβάστε προσεκτικά τις οδηγίες χρήσης πριν από τη χρήση του Κλιματιστικού.

- Φροντίστε να προμηθευτείτε το "Εγχειρίδιο Ιδιοκτήτη" και το "Εγχειρίδιο Εγκατάστασης" από τον κατασκευαστή (ή τον πωλητή).

Ζητήστε από τον κατασκευαστή ή τον πωλητή

- Να σας εξηγήσει με σαφήνεια τα περιεχόμενα του Εγχειριδίου Ιδιοκτήτη πριν σας το παραδώσει.

ADOPÇÃO DO NOVO REFRIGERANTE

O presente aparelho de ar condicionado é um novo tipo que adopta o novo refrigerante HFC (R410A) em vez do refrigerante convencional R22. O R410A é um refrigerante que não prejudica o ozono.

Agradecemos o facto de ter adquirido este aparelho de ar condicionado da TOSHIBA.

Lei atentamente o presente manual do utilizador antes de utilizar o aparelho de ar condicionado.

- Peça o "Manual do Utilizador" e o "Manual de Instalação" ao técnico de instalação (ou concessionário).

Peça ao técnico de instalação ou representante

- que explique claramente o conteúdo do Manual do Utilizador antes de proceder à sua entrega.

ВНЕДРЕНИЕ НОВОГО ХЛАДАГЕНТА

Данный кондиционер является кондиционером нового типа, в котором предусмотрено использование нового хладагента HFC (R410A) вместо традиционного R22. R410A – хладагент, не разрушающий озоновый слой.

Благодарим вас за покупку кондиционера TOSHIBA.

Внимательно прочитайте данное руководство пользователя перед началом использования кондиционера.

- Проверьте наличие "Руководства пользователя" и "Руководства по установке" в комплекте, поставляемом монтажной организацией (или дилером).

Попросите монтажную организацию или дилера

- Подробно объяснить содержание Руководство пользователя до его передачи.

ANVÄNDANDE AV NY KYLVÄTSKA

Denna luftkonditioneringsapparat är en ny typ som använder den nya kylvätskan HFC (R410A) i stället för den vanliga kylvätskan R22. R410A är en kylvätska som inte är skadlig för ozonskiktet.

Tack för att du ville köpa denna luftkonditioneringsapparat från TOSHIBA. Läs denna bruksanvisning noga innan du använder luftkonditioneringsapparaten.

- Försäkra dig om att du får "BRUKSANVISNING" och "INSTALLATIONSHANDBOK" från installationsteknikern (eller återförsäljaren).

Be installationsteknikern eller återförsäljaren

- Att tydligt förklara innehållet i BRUKSANVISNINGEN innan han lämnar över den.

CONTENTS

ACCESSORIES (SOLD SEPARATELY)	1	HIGH POWER OPERATION	11
PRECAUTIONS FOR SAFETY	1	ECO (1, 3, 5, 9H OFF) TIMER	11
PARTS NAME	3	TIMER OPERATION	12
PARTS NAME OF RECEIVER SECTION	4	MEMORY/PRESET OPERATION	14
PARTS NAME OF REMOTE CONTROLLER	5	ADJUSTING AIR FLOW DIRECTION	15
NAMES AND FUNCTIONS OF INDICATIONS ON THE REMOTE CONTROLLER	6	HOW TO USE THE AIR CONDITIONER WORKS	15
PREPARATION AND CHECK BEFORE USE	7	TEMPORARY OPERATION	17
HANDLING THE REMOTE CONTROLLER	8	MAINTENANCE	18
AUTOMATIC OPERATION	9	AIR CONDITIONER OPERATIONS AND PERFORMANCE	19
AUTOMATIC OPERATION (AUTO CHANGEOVER)	9	RE-INSTALLATION	20
COOLING/HEATING/FAN ONLY OPERATION	10	TROUBLES AND CAUSES	20
DRY OPERATION	10	TROUBLE AND CAUSES (Concerning Remote Controller)	22

SOMMAIRE

ACCESSOIRES (VENDUS SEPARÉMENT)	23	FONCTIONNEMENT A HAUTE PUISSANCE	33
MESURES DE SECURITE	23	MINUTERIE ECO (1, 3, 5, 9H DESACTIVATION)	33
NOM DES PIECES	25	FONCTIONNEMENT PAR MINUTERIE	34
NOM DES PIECES DE LA TELECOMMANDE	27	MEMORISATION / PROGRAMMATION	35
NOM ET FONCTIONS DES INDICATIONS DE LA TELECOMMANDE	28	REGLAGE DU SENS DE DIFFUSION DE L'AIR	37
PREPARATION ET VERIFICATION AVANT UTILISATION	29	COMMENT FONCTIONNE LE CLIMATISEUR	38
MANIPULATION DE LA TELECOMMANDE	30	FONCTIONNEMENT TEMPORAIRE	39
FONCTIONNEMENT AUTOMATIQUE	31	FONCTIONNEMENT ET PERFORMANCES DU CLIMATISEUR	41
FONCTIONNEMENT AUTOMATIQUE (CHANGEMENT AUTOMATIQUE)	31	REINSTALLATION	42
REFROIDISSEMENT / CHAUFFAGE / VENTILATION SEULE	32	TROUBLES ET CAUSES	42
DESHUMIDIFICATION	32	PROBLEMES ET CAUSES (concernant la télécommande)	44

INHALT

ZUBEHÖR (GESONDERT ERHÄLTLICH)	45	HÖCHLEISTUNGSBETRIEB	55
SICHERHEITSVORBEREITUNG	45	ECO (1, 3, 5, 9H OFF) TIMER	55
TEILBEZEICHNUNGEN	47	ZEITVORGABEN	56
TEILBEZEICHNUNG DES EMPFÄNGERS	48	BETRIEBSART SPEICHER/VOREINSTELLUNG	58
TEILBEZEICHNUNG DER FERNBEDIENUNG	48	REGULIERUNG DER LUFTSTROMRICHTUNG	59
BEZEICHNUNGEN UND FUNKTIONEN AUF DER FERNBEDIENUNGS-ANZEIGE	50	ARBEITSWEISE DES KLIMAGERÄTS	60
VORBEREITUNGEN UND TESTS VOR DER INBETRIEBNAHME	51	VORÜBERGEHENDER BETRIEB	61
HANDHABUNG DER FERNBEDIENUNG	52	WARTUNG	62
AUTOMATISCHER BETRIEB	53	RE-INSTALLATION UND LEISTUNG DES KLIMAGERÄTS	63
AUTOMATISCHER BETRIEB (AUTOMATISCHER WECHSEL)	53	NEU-INSTALLATION	64
BETRIEBSART HEIZEN / KÜHLEN / NUR VENTILATOR	54	STÖRUNGEN UND IHRE URSACHEN	64
BETRIEBSART ENTFEUCHTEN	54	STÖRUNGEN UND IHRE URSACHEN (Fernbedienung)	66

INDICE

ACCESSORI (DA ACQUISTARE A PARTE)	67	FUNZIONAMENTO AD ALTA POTENZA	77
PRECAUZIONI PER LA SICUREZZA	67	TIMER ECO (1, 3, 5, 9H OFF)	77
NOME DELLE PARTI	69	FUNZIONAMENTO CON TIMER	78
NOME DELLE PARTI DEL RICEVITORE	70	MEMORIA / FUNZIONAMENTO PREIMPOSTATO	80
NOME DELLE PARTI DEL TELECOMANDO	71	COME REGOLARE LA DIREZIONE DEL FLUSSO D'ARIA	81
NOME E FUNZIONE DELLE INDICAZIONI VISUALIZZATE SUL TELECOMANDO	72	MODI DI FUNZIONAMENTO DEL CONDIZIONATORE D'ARIA	82
PREPARAZIONE E CONTROLLO PRIMA DELL'USO	73	FUNZIONAMENTO TEMPORANEO	83
USO DEL TELECOMANDO	74	MANUTENZIONE	84
FUNZIONAMENTO AUTOMATICO	75	OPERAZIONI E PRESTAZIONI DEL CONDIZIONATORE D'ARIA	85
FUNZIONAMENTO AUTOMATICO (COMMITTAZIONE AUTOMATICA)	75	FUNZIONAMENTO TEMPORANEO	85
RAFFREDDAMENTO / RISCALDAMENTO / FUNZIONAMENTO CON SOLA VENTOLA	76	PROBLEMI E CAUSE	86
FUNZIONAMENTO DI DEUMIDIFICAZIONE	76	PROBLEMI E CAUSE (Riguardanti il telecomando)	88

CONTENIDO

ACCESORIOS	89	FUNZIONAMENTO CON POTENCIA ELEVADA	99
PRECAUCIONES DE SEGURIDAD	89	TEMPORIZADOR ECO (1, 3, 5, 9H APAGADO)	99
NOMBRE DE LOS COMPONENTES	91	FUNZIONAMENTO DEL TEMPORIZADOR	100
DESCRIPCION DE LOS BOTONES DE LA SECCION DEL RECEPTOR	92	MEMORIA/FUNZIONAMENTO PRESELECCIONADO	101
DESCRIPCION DE LOS BOTONES DEL CONTROL REMOTO	93	AJUSTE DEL SENTIDO DE CIRCULACION DEL AIRE	103
NOMBRE Y FUNCIONES DE LOS INDICADORES DEL CONTROL REMOTO	94	COMO FUNCIONA EL APARATO DE AIRE ACONDICIONADO	104
PREPARACION Y PRUEBA ANTES DEL USO	95	FUNZIONAMENTO TEMPORAL	105
USO DEL CONTROL REMOTO	96	FUNZIONAMENTO TEMPORANEO	106
FUNZIONAMENTO AUTOMATICO	97	FUNCIONES Y RENDIMIENTO DEL APARATO DE AIRE ACONDICIONADO	107
FUNZIONAMENTO AUTOMATICO (CAMBIO AUTOMATICO)	97	REINSTALACION	108
FUNZIONAMENTO DE REFRIGERACION/CALEFACCION/SOLO VENTILADOR	98	PROBLEMAS Y CAUSAS	108
FUNZIONAMENTO CON AIRE SECO	98	PROBLEMAS Y CAUSAS (Relacionadas con el control remoto)	110

ΠΕΡΙΕΧΟΜΕΝΑ

ΠΑΡΕΛΚΟΜΕΝΑ (ΠΟΛΥΠΛΗΡΕΣ ΕΞΟΡΧΙΣΤΑ)	111	ΛΕΙΤΟΥΡΓΙΑ ΥΨΗΛΗΣ ΙΣΧΥΟΣ	121
ΠΡΟΦΥΛΑΞΕΙΣ ΑΣΦΑΛΕΙΑΣ	111	ΛΕΙΤΟΥΡΓΙΑ ΕΚΚΛΕΚΤΩΝ ΧΡΟΝΟΔΙΑΚΟΠΤΗΣ	122
ΟΝΟΜΑ ΤΜΗΜΑΤΩΝ	113	ΛΕΙΤΟΥΡΓΙΑ ΧΡΟΝΟΔΙΑΚΟΠΗΣ	122
ΟΝΟΜΑΤΑ ΤΜΗΜΑΤΩΝ ΤΟΥ ΔΕΚΤΗ	114	ΛΕΙΤΟΥΡΓΙΑ ΜΝΗΜΗΣ / ΠΡΟΚΑΘΟΡΙΣΜΟΥ	124
ΟΝΟΜΑΤΑ ΤΜΗΜΑΤΩΝ ΤΟΥ ΤΗΛΕΧΕΙΡΙΣΤΗΡΙΟΥ	115	ΔΙΟΡΘΩΣΗ ΤΗΣ ΚΑΤΕΥΘΥΝΣΗΣ ΡΟΗΣ ΤΟΥ ΑΕΡΑ	125
ΟΝΟΜΑ ΚΑΙ ΛΕΙΤΟΥΡΓΙΕΣ ΤΩΝ ΕΝΔΕΙΞΕΩΝ ΤΟΥ ΤΗΛΕΧΕΙΡΙΣΤΗΡΙΟΥ	116	ΠΩΣ ΛΕΙΤΟΥΡΓΕΙ ΤΟ ΚΛΙΜΑΤΙΣΤΙΚΟ	126
ΠΡΟΤΙΜΑΣΙΑ ΚΑΙ ΕΛΕΓΧΟΣ ΠΡΙΝ ΑΠΟ ΤΗ ΧΡΗΣΗ	117	ΠΡΟΧΩΡΙΝΗ ΛΕΙΤΟΥΡΓΙΑ	127
ΧΕΙΡΙΣΜΟΣ ΤΟΥ ΤΗΛΕΧΕΙΡΙΣΤΗΡΙΟΥ	118	ΣΥΝΤΗΡΗΣΗ	128
ΑΥΤΟΜΑΤΗ ΛΕΙΤΟΥΡΓΙΑ	119	ΚΑΤΑΡΤΙΣΗ ΚΑΜΑΤΙΣΤΙΚΟΥ ΚΑΙ ΑΠΟΔΟΣΗ	129
ΑΥΤΟΜΑΤΗ ΛΕΙΤΟΥΡΓΙΑ (ΑΥΤΟΜΑΤΗ ΜΕΤΑΒΟΛΗ)	119	ΕΓΚΑΤΑΣΤΑΣΗ ΕΚ ΝΕΟΥ	130
ΨΥΞΗ / ΘΕΡΜΑΝΣΗ / ΛΕΙΤΟΥΡΓΙΑ ΜΟΝΟ ΑΝΕΜΙΣΤΗΡΑ	120	ΠΡΟΒΛΗΜΑΤΑ ΚΑΙ ΑΙΤΙΑ	130
ΞΗΡΗ ΛΕΙΤΟΥΡΓΙΑ	120	ΠΡΟΒΛΗΜΑΤΑ ΚΑΙ ΑΙΤΙΑ (Σχετικά με το Τηλεχειριστήριο)	132

ÍNDICE

ACCESÓRIOS (VENDIDO SEPARADAMENTE)	133	OPERAÇÃO DE ALTA POTÊNCIA	143
PRECAUCOES DE SEGURANCA	133	ECO (1, 3, 5, 9H DESLIGAR) TEMPORIZADOR	143
NOME DAS PARTES	135	OPERAÇÃO DO REGULADOR	144
NOME DAS PEÇAS DA SEÇÃO RECEPTORA	136	OPERAÇÃO MEMÓRIA / PRÉ-AJUSTE	146
NOMES DAS PARTES DO CONTROLE REMOTO	137	REGULAR A DIREÇÃO DO CAUDAL DE AR	147
NOME E FUNCOES DAS INDICAÇÕES NO CONTROLE REMOTO	138	MODOS DE FUNCIONAMENTO DO APARELHO DE AR CONDICIONADO	148
PREPARAÇÃO E VERIFICAÇÃO ANTES DO USO	139	OPERAÇÃO TEMPORÁRIA	149
MANUSEIO DO CONTROLE REMOTO	140	MANUTENÇÃO	150
OPERAÇÃO AUTOMÁTICA	141	OPERAÇÃO E FUNCIONAMENTO DO AR CONDICIONADO	151
OPERAÇÃO AUTOMÁTICA (CONVERSAO AUTOMÁTICA)	141	REINSTALAÇÃO	152
OPERAÇÃO DE REFRIGERAÇÃO / AQUECIMENTO / APENAS VENTILADOR	142	PROBLEMAS E CAUSAS	152
OPERAÇÃO DE SECAGEM	142	PROBLEMAS E CAUSAS (Relativos ao Controle Remoto)	154

СОДЕРЖАНИЕ

ДОПОЛНИТЕЛЬНЫЕ ПРИНАДЛЕЖНОСТИ (ПРОДАЮТСЯ ОТДЕЛЬНО)	155	РАБОТА В РЕЖИМЕ БОЛЬШОЙ МОЩНОСТИ	155
ПРАВИЛА ТЕХНИКИ БЕЗОПАСНОСТИ	155	ТАЙМЕР ECO (ВЫКЛЮЧЕНИЕ ЧЕРЕЗ 1, 3, 5, 9 ЧАСОВ)	156
НАИМЕНОВАНИЕ ДЕТАЛЕЙ	157	РАБОТА ТАЙМЕРА	156
НАИМЕНОВАНИЕ ДЕТАЛЕЙ СЕКЦИИ ПРИЕМНИКА	158	РАБОТА С ПАМЯТЬЮ/ПРЕДУСТАНОВКАМИ	158
НАИМЕНОВАНИЕ ДЕТАЛЕЙ ПУЛЬТА ДИСТАНЦИОННОГО УПРАВЛЕНИЯ	159	РЕГУЛИРОВКА НАПРАВЛЕНИЯ ВОЗДУШНОГО ПОТОКА	159
НАЗВАНИЯ И ФУНКЦИИ РЕЖИМОВ ИНДИКАЦИИ НА ПУЛЬТЕ ДИСТАНЦИОННОГО УПРАВЛЕНИЯ	160	ПРИНЦИП РАБОТЫ КОНДИЦИОНЕРА	170
ПОДГОТОВКА И ПРОВЕРКА ПЕРЕД НАЧАЛОМ ЭКСПЛУАТАЦИИ	161	ВРЕМЕННАЯ РАБОТА	171
ОБРАЩЕНИЕ С ПУЛЬТОМ ДИСТАНЦИОННОГО УПРАВЛЕНИЯ	162	ТЕХНИЧЕСКОЕ ОБСЛУЖИВАНИЕ	172
АВТОМАТИЧЕСКАЯ РАБОТА	163	ЭКСПЛУАТАЦИЯ КОНДИЦИОНЕРА И ПРОИЗВОДИТЕЛЬНОСТЬ	173
АВТОМАТИЧЕСКАЯ РАБОТА (АВТОМАТИЧЕСКОЕ ПЕРЕКЛЮЧЕНИЕ)	163	ПОВТОРНАЯ УСТАНОВКА	174
ОХЛАЖДЕНИЕ/НАГРЕВ/РАБОТА ТОЛЬКО ВЕНТИЛЯТОРА	164	НЕИСПРАВНОСТИ И ПРИЧИНЫ	174
РАБОТА В РЕЖИМЕ ОСУШЕНИЯ	164	НЕИСПРАВНОСТИ И ПРИЧИНЫ (относятся к пульту дистанционного управления)	176

INNEHÅLL

TILLBEHÖR (SÄLJES SEPARAT)	177	FUNKTION MED HÖG EFFEKT	187
FÖRSIKTIGHETSÅTGÄRDER SOM GÄLLER SÄKERHETEN	177	ECO (1, 3, 5, 9H OFF) TIMER	187
DELARNAS BENÄMNING	179	TIMERFUNKTION	188
DELARNAS BENÄMNING I MOTTAGNINGSEKSIONEN	180	FUNKTION MINNE/FÖRINSTÄLLNING	190
FJÄRRKONTROLLENS FUNKTIONER	181	HUR LUFTKONDITIONERINGSAPPARATEN FUNGERAR	191
NAMN OCH FUNKTIONER FÖR FJÄRRKONTROLLENS INDIKATIONER	182	HUR LUFTKONDITIONERINGSAPPARATEN FUNGERAR	192
FÖRBEREDELSE OCH KONTROLL FÖRE ANVÄNDNINGEN	183	TILLFÄLLIG FUNKTION	193
ATT HANTERA FJÄRRKONTROLLEN	184	UNDERHÅLL	194
AUTOMATISK FUNKTION	185	LUFTKONDITIONERINGSAPPARATENS FUNKTION OCH PRESTANDA	195
AUTOMATISK FUNKTION (AUTOMATISK VÄXLING)	185	OMINSTALLATION	196
LUFTKONDITIONERANDE/UPPVÄRMANDE/FLÄKT FUNKTION	186	PROBLEM OCH FELSÖKNING	196
LUFTTORKNINGSFUNKTION	186	PROBLEM OCH FELSÖKNING (för fjärrkontrollen)	198

ENGLISH

FRANCAIS

DEUTSCH

ITALIANO

ESPAÑOL

ΕΛΛΗΝΙΚΑ

PORTUGUÊS

РУССКИЙ

SVENSKA

ACCESSORIES (SOLD SEPARATELY)

Remote controller

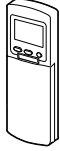

Remote controller holder



Battery (two pcs.)



Standard 4-way cassette panel optional parts

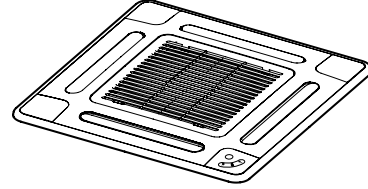

PRECAUTIONS FOR SAFETY

⚠ WARNING

WARNINGS ABOUT INSTALLATION

- Ensure installation is carried out by a qualified professional. If the unit is incorrectly installed there is a risk of water damage, electric shock or fire.
- Ensure unit is earthed correctly. Do not connect earth wiring to gas pipes, water pipes, lightning rods or earths provided for telephone cables.



CAUTION

TO DISCONNECT THE APPLIANCE FROM THE MAIN SUPPLY

A switch or circuit breaker that can disconnect all poles must be included in the fixed wiring. Be sure to use an approved circuit breaker or switch.

The installation fuse (16A) must be used for the power supply of this air conditioning system.

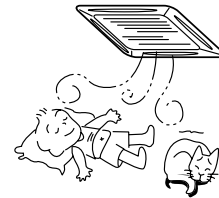

WARNINGS ABOUT OPERATION

- Cleaning of the air filter and other parts of the air filter can involve dangerous work at heights. Ensure to this work is carried out by service engineer. Do not attempt this yourself. The cleaning diagram for the air filter is detailed for the service engineer, and not for the customer.
- Be aware of the potential health issues which could arise due to the exposure of the human body to cold draughts or by over-cooling the room.
- When you notice something abnormal with the air conditioner (smells like something scorching poor cooling, etc.), immediately turn off the main switch and the circuit breaker from the mains to stop the air conditioner. Contact the dealer. If the air conditioner is continuously operated abnormally, it may cause machine failure, electric shock or fire.

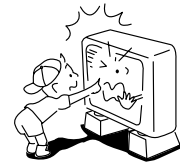

WARNINGS ABOUT MOVEMENT AND REPAIR

- Do not move or repair any unit by yourself. This must be carried out by a qualified professional.
- Whenever the air conditioner needs repair, make sure that you consult your dealer. If the unit is repaired incorrectly this could cause possible electric shock or fire.
- When moving the air conditioner for reinstallation in another location consult your dealer. An incorrect installation may cause electric shock or fire.

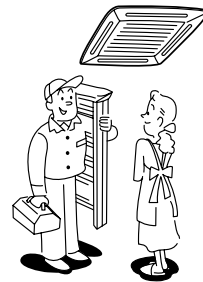

CAUTION

CAUTIONS ABOUT INSTALLATION

- Ensure to confirm the following cautions.
- Ensure that the condensate drainage is sealed throughout the system to prevent any possible water damage.
- Ensure that the air conditioner is connected to a separate power supply of the correct voltage.
- Do not install the unit in a place where flammable gases may leak. If flammable gas accumulates around the unit, this may cause a fire.

CAUTIONS ABOUT OPERATION

- Carefully read this manual before starting the air conditioner. There are many important things to keep in mind during daily operation.
- Do not use this air conditioner for special purposes such as preserving food, precision instruments, art objects, breeding animals, growing potted plants, etc.
- Avoid exposing potted plants and animals to the air flow of the air conditioner, since it can affect their health and growth.
- When the air conditioner is operated in close proximity to a combustion device, pay careful attention to ventilation and let fresh air into the room. Poor ventilation causes oxygen shortage.
- Do not place any combustion appliance in a place where it is directly exposed to the air flow of the air conditioner, otherwise it may cause a combustion.
- When the air conditioner is used in a closed room, be careful to ensure sufficient ventilation within the room. Poor ventilation causes oxygen shortage.
- Do not touch any switches with wet hands; otherwise you may get an electric shock.
- If the air conditioner won't be used for a considerably long time, turn off the main power supply at the circuit breaker for safety.
- Check the concrete blocks, etc. of the base of the outdoor unit occasionally. If the base is left damaged or deteriorated, the unit may topple over and inflict an injury to a person as a worst case.
- Do not put anything on the outdoor unit nor step onto it. If you do, it may not only topple over, but could cause injury to yourself.
- To make the air conditioner operate at its original performance, operate it within the range of the operating temperature specified in the instructions. Otherwise this may cause a malfunction or a water leak from the unit.
- Prevent any liquid from falling on to the remote controller.

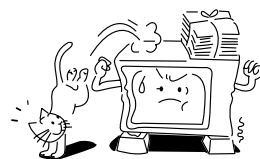
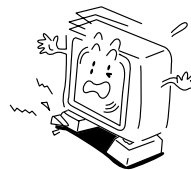
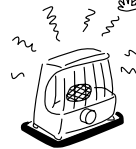
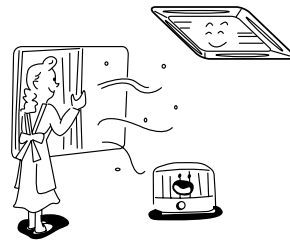
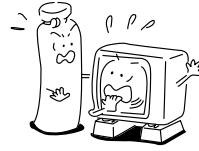
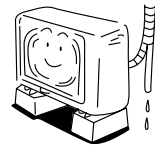

PARTS NAME

Indoor unit

Button

Button to open/close the suction grille

Earth screw

Located in the electric parts box

Discharge louver of discharge port

Change the direction of the air to be discharged according to cool/heat mode.

Suction inlet grille

The air in the room is sucked in through this grille.

Receiver section

Remote controller

Air filter

Removes dust particles. (Attached to inlet grille.)

Protrusion on air filter

Outdoor unit

Air inlet (Side and rear)

Pipes and electric wires

Air outlet

PARTS NAME OF RECEIVER SECTION

Receiver section

Display panel

The operating conditions are shown below.

- 1** RESET button
- 2** OPERATION indicator (Green)
The operation indicators flash rapidly (5 times per second) when a safety protection feature is activated.
- 3** TIMER indicator (Yellow)
- 4** Remote controller sensor

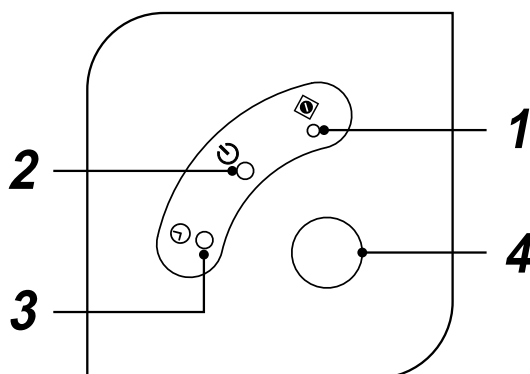

RESET button

If you misplace or loose the remote controller or the batteries are fully discharged, push the RESET button.

1. Push the RESET button to start the automatic operation (AUTO). Push this button again to stop operation. See page 17.

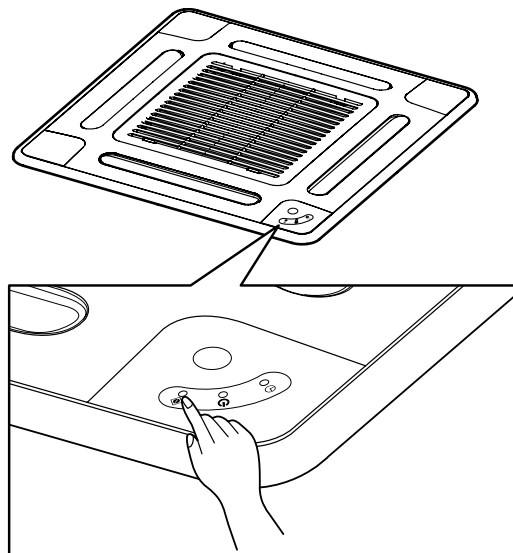

PARTS NAME OF REMOTE CONTROLLER

1 START/STOP button

Push the button to start operation.
(A receiving beep is heard.)

Push the button again to stop operation.
(A receiving beep is heard.)

If no sound is heard from the receiver, push the button again.

2 Mode select button (MODE)

Push this button to select a mode.

Each time you push the button, a mode is selected in a sequence.

A : Auto changeover control, ❄ : Cool,

☀ : Dry, ☀ : Heat (for Heat pump model only),

🌀 : Fan only (For Cooling only model), and back to A. (A receiving beep is heard.)

3 Temperature button (▲ ▼)

▲ The set temperature can be raised to 30°C.

▼ The set temperature can be lowered to 17°C.
(A receiving beep is heard.)

4 Fan speed button (FAN)

Push this button to select fan speed. When you select AUTO, the fan speed is automatically adjusted according to the room temperature.

You can also manually select the desired fan speed. There are five settings.

(LOW ▬, LOW+ ▬▬, MED ▬▬▬, MED+ ▬▬▬▬, HIGH ▬▬▬▬▬) (A receiving beep is heard.)

5 Auto louver button (SWING)

Push this button to swing the louver.
(A receiving beep is heard.)

Push the SWING button to stop the louver swinging.
(A receiving beep is heard.)

6 Set louver button (FIX)

Push this button to adjust the air flow direction.
(A receiving beep is heard.)

7 Off timer button (OFF)

Push this button to set the OFF timer.

8 On timer button (ON)

Push this button to set the ON timer.

9 Reserve button (SET)

Push this button to reserve time settings.
(A receiving beep is heard.)

10 Cancel button (CLR)

Push this button to cancel ON timer and OFF timer. (A receiving beep is heard.)

CAUTION

- When pushing the "FILTER" button.

The indoor unit does not operate and the receiver does not sound a beep.

11 High power button (Hi POWER)

Push this button to start the high power operation.

12 Memory button (MEMO)

Push this button to store the settings.

Push the button again for 3 seconds or more to store the setting indicated on the remote controller and ● mark is indicated.
(Refer to "MEMORY/PRESET OPERATION")

13 ECO timer button (ECO)

Push this button to start the ECO timer (OFF timer) operation.

You can select the OFF timer duration.
There are four settings (1, 3, 5 or 9 hours).

14 PRESET button

Push this button to operate the air conditioner according to the settings memorized by the MEMO button.

15 TIMER button

Use this button to change the clock, to set the On and Off durations.

To forward the time, push the "TIMER ▲" button.

To set back the time, push the "TIMER ▼" button.

16 Automatic operation button (AUTO)

Push this button to operate the air conditioner automatically. (A receiving beep is heard.)
(Refer to "AUTOMATIC OPERATION")

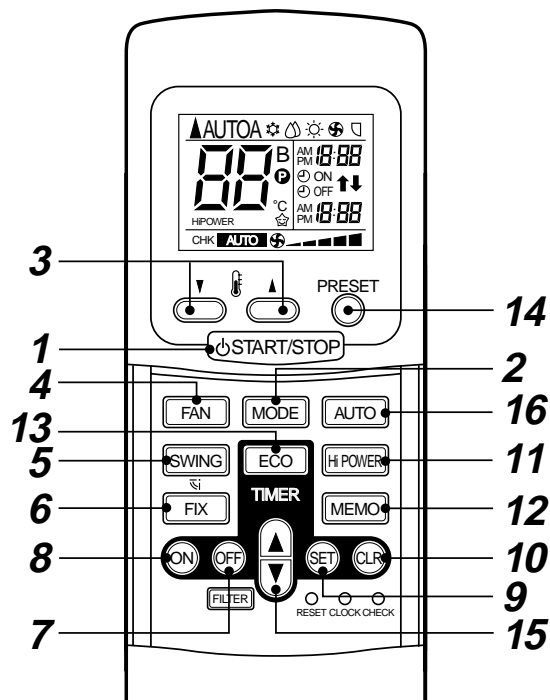

NAMES AND FUNCTIONS OF INDICATIONS ON THE REMOTE CONTROLLER

Display

All indications, except for the clock indication, are displayed by pushing the START/STOP button.

1 Transmission mark

This transmission mark ▲ indicates when the remote controller transmits a signal to the indoor unit.

2 Mode display

Indicates the current operation mode.

- Heat Pump model
(AUTO : Automatic control, A : Auto changeover control, ❄️ : Cool, 💧 : Dry, ☀️ : Heat)
- Cooling Only model
(AUTO : Automatic control, A : Auto changeover control, ❄️ : Cool, 💧 : Dry, 🌀 : Fan only)

3 Temperature display

Indicates the temperature setting (17°C to 30°C).
When you set the operating mode to 🌀 : Fan only, no temperature setting is displayed. (for Cooling only model)

4 FAN speed display

Indicates the selected fan speed.
AUTO or one of five fan speed levels (LOW 📊, LOW+ 📊, MED 📊, MED+ 📊, HIGH 📊) can be displayed.

AUTO is displayed when the operating mode is either in AUTO or 💧 : Dry.

5 TIMER and clock display

The time set for timer operation or the clock is displayed.

The present time is always indicated except when in TIMER operation.

6 High power display

Indicates when the High power operation starts.
Push the Hi POWER button to start and stop the operation.

7 Ⓜ (MEMORY) display

Flashes for 3 seconds when the MEMO button is pushed during operation.

Ⓜ mark is displayed when the button is not pushed for more than 3 seconds while the mark is flashing.

Push another button to turn off the mark.

8 ECO TIMER display

Indicates when the ECO TIMER is in operation.
Each time you push the ECO button, the display changes in sequence between 1, 3, 5, or 9h.

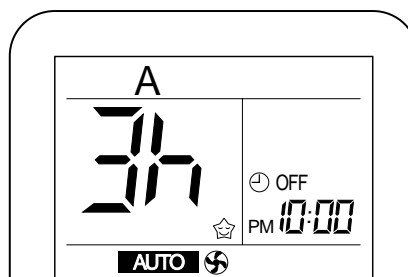

9 A, B change indicator remote controller

When the remote controller switching function is set, "B" appears on the remote controller display. (When the remote controller setting is "A" there is no indication in this position.)

Remote controller switching function

- If two indoor units are installed in the same room or adjoining rooms, both units may start and stop at the same time when the remote controller is operated. This can be prevented by setting the switching function so that each indoor unit is operated only by the corresponding remote controller.
- To use the remote controller switching function, contact the air conditioner dealer or the installation company.

Resetting of the remote controller switching

To exchange the battery while using remote controller switching function, reset the remote controller switching.

- Exchange the battery with a new one.
- Push the "CHECK" point and "MODE" button at the same time, to change the remote controller setting from "A" to "B". (Priority is given to "A" setting.)
- Check that the changed remote controller can or cannot operate the indoor unit.

- In the illustration, all indications are indicated for explanation.
During operation, only the relevant indications will be displayed on the remote controller.

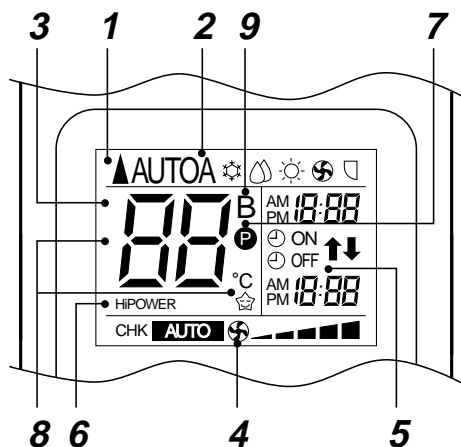

PREPARATION AND CHECK BEFORE USE

Loading the remote controller batteries.

1 Remove the cover and insert the batteries.

- Slide off the cover while pushing the sides.

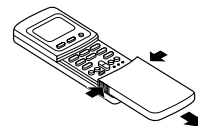

2 Push the RESET button.

The clock display flashes. Adjust the clock.
Place back the cover.

• Battery replacement

- Be careful not to reverse the (+) position and the (-) position.

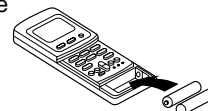

Batteries

- To replace the batteries, use two new batteries (AAA type).
- In normal use, the batteries last about one year.
- Replace the batteries if there is no beep from the receiver of the indoor unit or when the air conditioner cannot be operated using the remote controller.
- To avoid malfunctions caused by battery leakage, remove the batteries when not using the remote controller for over one month.

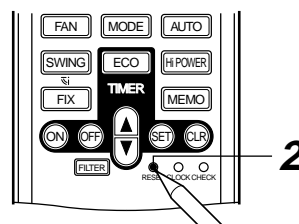

Setting the clock

Before you start operating the air conditioner, set the clock of the remote controller using the procedures given in this section. The clock panel on the remote controller indicates the time regardless of whether the air conditioner is in use or not.

Initial setting

When batteries are inserted in the remote controller, the clock panel indicates AM 0:00 and flashes.

1 **TIMER** button

Push the **TIMER** button to set the current time.

Each time the **TIMER** button is pushed, it changes the time on one minute basis.

When the **TIMER** button is held down, it changes the time on one ten minutes basis.

2 **SET** button.

Push the **SET** button.

The current time is displayed and the clock starts.

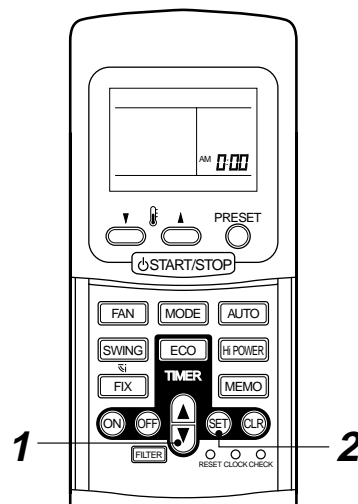

Clock adjusting

1 **CLOCK** button

Push the **CLOCK** button.

The **CLOCK** display flashes.

2 **TIMER** button.

Push the **TIMER** button to set the current time.

Each push of the **TIMER** button changes the time by one minute.

Holding down the **TIMER** button changes the time by ten minutes.

3 **SET** button.

Push the **SET** button.

The current time is displayed and the clock starts.

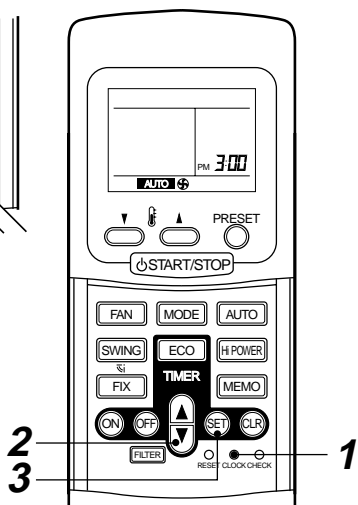
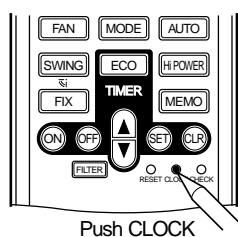

HANDLING THE REMOTE CONTROLLER

CAUTION

- The air conditioner will not operate if curtains, doors or other materials are blocking the signals sent from the remote controller to the indoor unit.
- Prevent any liquid from falling onto the remote controller.
- If the infrared signal receiver on the switch panel is exposed to direct sunlight, the air conditioner may not function properly.

Use curtains to prevent direct sunlight being exposed to the receiver.

- If the air conditioner is installed in a room which has fluorescent lights with electronic starters or inverter systems, signals may not be properly received and the air conditioner cannot start or stop while the lights are on.

If you plan to use the fluorescent lights in the same room where the air conditioner operates, consult your local dealer.

- If other electrical appliances react to the remote controller of the air conditioner, either remove these appliances or consult your local dealer.

Location of the remote controller

- Keep the remote controller where its signals can reach the receiver on the panel. (maximum distance is 7 m)
- When you select the timer operation, the remote controller automatically transmits a signal to the indoor unit at the specified time.

If you keep the remote controller in a position that hinders proper signal transmission, a time lag of up to 15 minutes may occur.

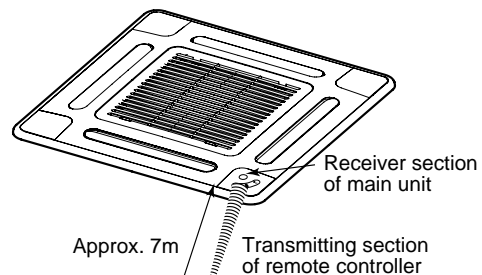

Remote controller holder

Installing the remote controller holder

- Before you install the remote controller holder on a wall or pillar, check whether the remote controller signals can be received by the indoor unit.

Mounting and removing the remote controller

- To mount the remote controller, hold it parallel to the remote controller holder and push it in fully.

To remove the remote controller, slide the remote controller upwards and take it out from the holder.



Receiver section of main unit

When the receiver section receives the signal, the receiver at the indoor unit sounds.

- ♪ pip, pip ♪ : Operation
- ♪ Long pip ♪ : Stop
- ♪ pip ♪ : Change

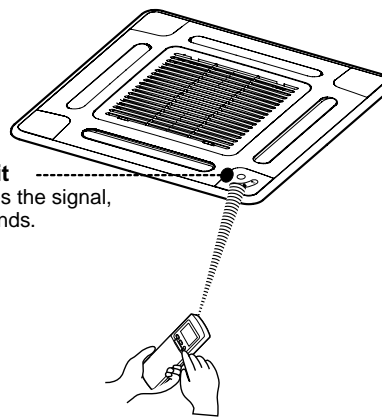

AUTOMATIC OPERATION

When you set the air conditioner in AUTO mode, it will automatically select either cooling, heating, or fan only operation depending on the outdoor temperature. (Refer to page 15.)

In addition, fan speed is automatically controlled.

Start

1 START/STOP button

Push this button to start the air conditioner.

2 AUTO button (AUTO)

Push AUTO button.

3 Temperature button (↑ ↓)

Set the desired temperature.

- The OPERATION lamp (green) on the panel of the indoor unit illuminates. The operating mode is selected in accordance with the room temperature and the operation starts after approximately 3 minutes.
- If the AUTO mode is uncomfortable, you can select the desired conditions manually.
- Fan speeds and louver position can be changed.
When it is changed, the MODE is also changed from AUTO to A.
At the same time, fan speed indication is displayed.

Stop

START/STOP button

Push this button to stop the air conditioner.

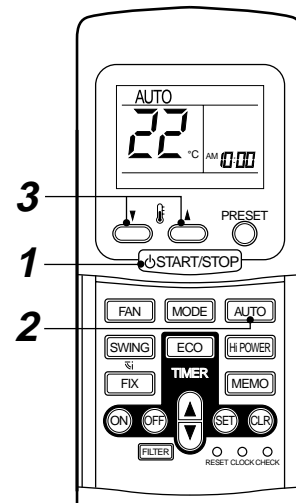

AUTOMATIC OPERATION (AUTO CHANGEOVER)

When you set the air conditioner in A mode or switch over from AUTO operation because setting may have been changed, it will automatically select either cooling, heating or fan only operation depending on the outdoor temperature. (Refer to page 15.)

Start

1 START/STOP button

Push this button to start the air conditioner.

2 Mode select button (MODE)

Select A.

3 Temperature button (↑ ↓)

Set the desired temperature.

4 Fan speed button (FAN)

Select one of "AUTO" LOW ▬, LOW+ ▬▬, MED ▬▬▬, MED+ ▬▬▬▬, HIGH ▬▬▬▬▬.

- The OPERATION indicator (green) on the panel of the indoor unit illuminates. The operating mode is selected according to the room temperature and operation starts after approximately 3 minutes.
- The temperature, fan speeds and louver position can be changed.
You can select the desired conditions manually.

Stop

START/STOP button

Push this button to stop the air conditioner.

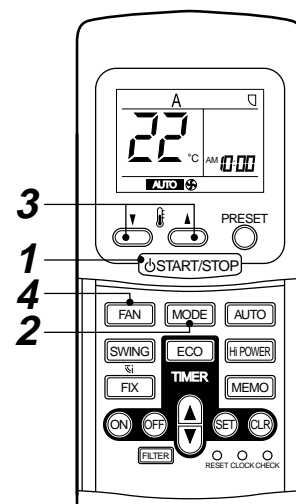

COOLING/HEATING/FAN ONLY OPERATION

Start

1 START/STOP button

Push this button to start the air conditioner.

2 Mode select button (MODE)

Select Cool ☀, Heat ☀ (For heat pump models), Fan only Ⓢ.
(For cooling only models)

3 Temperature button (↑ ↓)

Set the desired temperature.

When the air conditioner is in FAN ONLY operation, the temperature display is not displayed. (For cooling only models)

4 Fan speed button (FAN)

Select one of "AUTO", LOW ▾, LOW+ ▾▾, MED ▾▾▾, MED+ ▾▾▾▾, HIGH ▾▾▾▾▾.

- The OPERATION lamp (green) on the panel of the indoor unit illuminates. Operation starts after approximately 3 minutes. (If you select FAN ONLY mode, the unit will start immediately.)
- The Ⓢ : Fan only mode does not control temperature. Therefore, perform only steps **1**, **2** and **4** to select this mode.

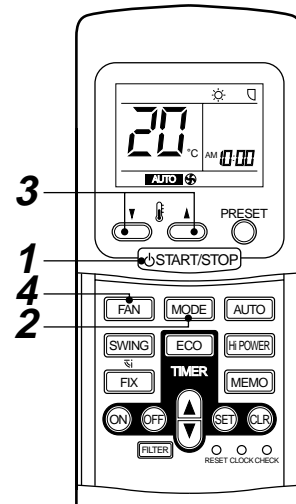

Stop

START/STOP button

Push this button to stop the air conditioner.

DRY OPERATION

Start

1 START/STOP button

Push this button to start the air conditioner.

2 Mode select button (MODE)

Select DRY ☹

3 Temperature button (↑ ↓)

Set the desired temperature.

- The fan speed display indicates AUTO.
- The OPERATION lamp (green) on the panel of the indoor unit illuminates, and operation starts after approximately 3 minutes.

Stop

START/STOP button

Push this button to stop the air conditioner.

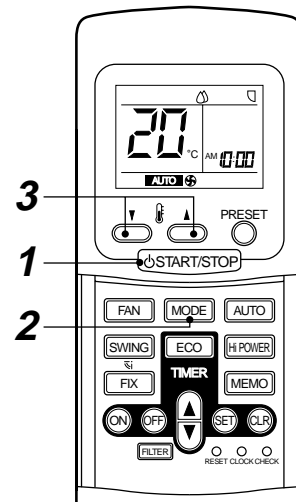

HIGH POWER OPERATION

High power (Hi POWER)

- The High power (High power operation) mode automatically controls room temperature, operation mode so that the room is quickly cooled in summer and warmed in winter. (Refer to page 15.)

Setting High power mode

1 Hi POWER button

- Push the Hi POWER button.
- The “Hi POWER” mark on the remote controller is displayed.

Canceling High power mode

1 Hi POWER button

- Push the Hi POWER button again.
- The “Hi POWER” mark on the remote controller goes out.

CAUTION

The High POWER mode cannot be activated in the DRY and FAN ONLY operation or when the ON TIMER operation is reserved.

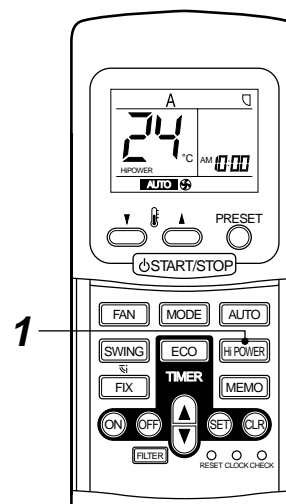

ECO (1, 3, 5, 9H OFF) TIMER

The air conditioner stops after operating for the set time (1, 3, 5 or 9 hours)

1 ECO button

- Push the ECO button (during operation).
- There is a short beep and the timer indicator comes on. The time at which the air conditioner will stop is indicated on the remote controller display (1H: about 1 hour after the current time).
- Push the button again while 1H is displayed (about 3 seconds) to change to the 3H indicator, push again to change to the 5H indicator, and push again to change to the 9H indicator.
- After selecting the time you want, do not push any other buttons. (When the 1H, 3H, etc. indicator goes off the timer is set.)

2 CLR button

- Push the CLR button to cancel the timer.
- The timer is cancelled but the air conditioner continues to operate.
- The 1, 3, 5 or 9H OFF timer operation is also cancelled if the OFF button is pushed after setting.

INFORMATION

- When using the timer in combination with the ON timer, first set 1, 3, 5 or 9H OFF timer and then set the ON timer.
- If the ECO button is pushed while the ON (OFF) timer has been set, the ON (OFF) timer is canceled and only the 1, 3, 5 or 9H OFF timer is set.

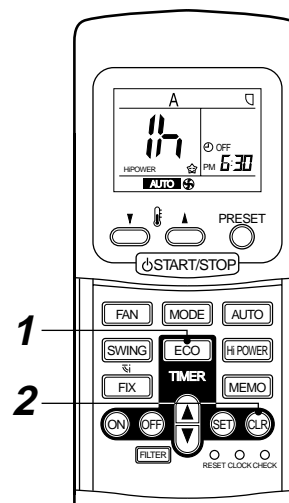

TIMER OPERATION

ON timer and OFF timer

Setting TIMER

1 ON/OFF TIMER button

Push the ON or OFF TIMER buttons as required.

- The previous timer setting is displayed and flashes at the same time as the ON/OFF TIMER display.

2 TIMER button

Push the TIMER  button.

Set the timer to the desired time.

Each push of the TIMER button changes the time by ten minute increments.

Pushing the TIMER button continually changes the time in one hour increments.

3 SET button

Push the SET  button to set the timer.

The set time for the timer is displayed and the timer starts.

4 CLR button

Push the CLR  button to cancel the timer setting.

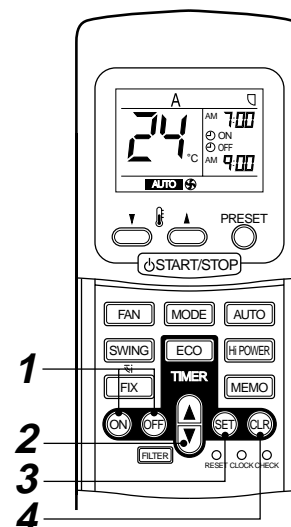

CAUTION

- When you select the timer operation, the remote controller automatically transmits the timer signal to the indoor unit at the specified time. Therefore, keep the remote controller in a location where it can transmit the signal to the panel properly.
- If you do not push the SET  button within 30 seconds after setting the time, the setting will be cancelled.

Once you select the timer operation mode, the settings are saved in the remote controller.

Thereafter, the air conditioner will start operating under the same conditions when you simply push the ON/OFF button of the remote controller.

If the clock display is flashing, you cannot set the timer.

Follow the instructions in the section "Setting the clock" on page 7 to set the clock and then set the timer.

Combined timer (Setting both ON and OFF timers simultaneously)





OFF timer → ON timer (Operation → Stop → Operation)

This feature is useful when you want to stop the air conditioner after you go to sleep or away from home and to start it again in the morning when you wake up or you return home.

Example:

To stop the air conditioner and start it again next morning.

Setting the combined TIMER

- 1) Push the OFF  button.
- 2) Push the TIMER  button to adjust the OFF timer.
- 3) Push the ON  button.
- 4) Push the TIMER  button to adjust the ON timer.
- 5) Push the SET  button.

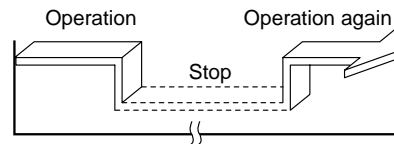





ON timer → OFF timer (Stop → Operation → Stop)

You can use this setting to start the air conditioner when you wake up and stop it when you leave the house.

Example:

To start the air conditioner next morning and stop the operation

Setting combined TIMER

- 1) Push the ON  button.
- 2) Push the TIMER  button to adjust the ON timer.
- 3) Push the OFF  button.
- 4) Push the TIMER  button to adjust the OFF timer.
- 5) Push the SET  button.

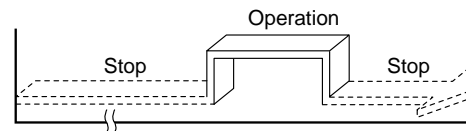

- Either ON or OFF timer function which ever is the closest to the current time is activated first.
- If the same time is set for both the ON and OFF timers, no timer operation is performed.











Also, the air conditioner may stop operating.

Every day combined timer

(Setting both ON and OFF timer simultaneously and activate every day.)

This feature is useful when you want to use combined timer at the same time every day.

Setting combined TIMER

- 1) Push the ON  button.
- 2) Push the TIMER  button to adjust the ON timer.
- 3) Push the OFF  button.
- 4) Push the TIMER  button to adjust the OFF timer.
- 5) Push the SET  button.
- 6) After step 5), an arrow mark ( or ) flashes for about 3 seconds, whilst flashing, push the SET  button.
 - When the every day timer is activated, both arrows (, ) are displayed.

Cancel the timer operation

Push the CLR  button.

Clock display

During the TIMER operation (ON-OFF, OFF-ON, OFF timer) the clock display is not displayed therefore not showing the setting time.

To see the present time, push SET button briefly.

The present time is displayed for about 3 seconds.

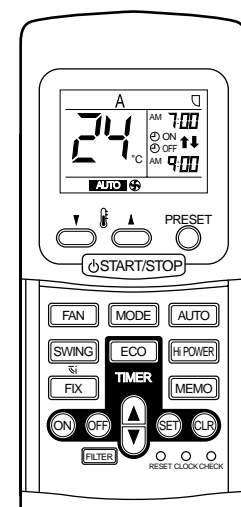

MEMORY/PRESET OPERATION

Store the frequently used operation setting by using the MEMO button for convenience.
 Start the air conditioner in the operation mode that you want the remote controller to memorize.
 Push the button as follows while the air conditioner is in operation.

1 MEMO button

Push this button briefly to store the setting.

All icons are currently displayed except for the clock display and  mark flashes.

2 MEMO button

Push and hold the MEMO button for more than 3 seconds while the display flashes.

The  mark is indicated and the setting is memorized.

- If you do not push the MEMO button within 3 seconds or if you push another button, the MEMORY setting is cancelled.
- Operation modes which can be memorized with using the MEMO button are MODE, Temperature, FAN, TIMER and High power.

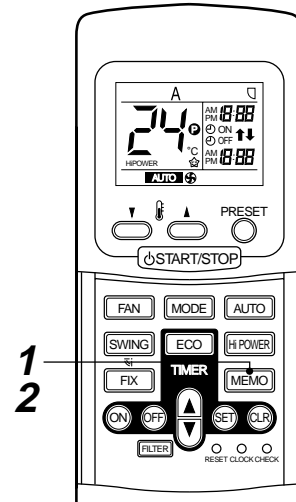

To operate the air conditioner with the setting stored using the MEMO button.

1 PRESET button

Push the PRESET button.

The setting stored by the MEMO button will be indicated and the air conditioner operates as per the setting.

- The OPERATION lamp (green) on the panel of the indoor unit is illuminated, and operation starts after approximately 3 minutes.
- Initial setting :

MODE : AUTO

Temperature : 22

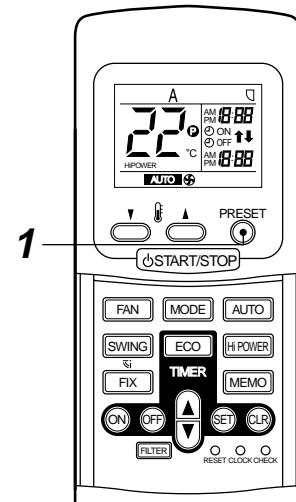

ADJUSTING AIR FLOW DIRECTION

- Adjust the air flow direction properly. Failure to do so could cause discomfort and cause uneven distribution of room temperature.
- When the air conditioner stops, the louver (adjustment plate of up/down air flow direction) directs upward automatically.
- In heating operation, when starting the operation/executing defrost operation or when the room temperature has reached the required set temperature, the fan stops or the air flow is vastly reduced and the louver directs upward.

During this time, even if the SWING button or the FIX button are pushed, the louver does not move as it directs upward. When starting the usual heating operation which blows hot air, the louver directs towards the set air flow direction.

Adjusting the air flow direction

The air conditioner automatically adjusts the air flow direction according to the operating conditions when AUTO or A mode is selected.

To set a selected air flow direction

Use this function when the air conditioner is operating.

1 FIX button

Hold down or briefly push the FIX button on the remote controller to move the louver to the desired direction.

- Change the air flow louver direction within the range that is displayed.
- In subsequent operations, the air flow is automatically set to the direction that you set the louver using the FIX button.

In HEAT/FAN ONLY operation

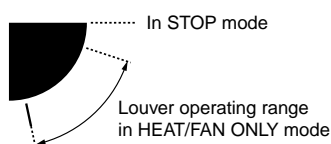

In COOL/DRY operation

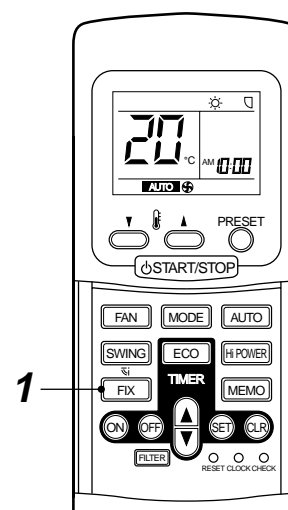
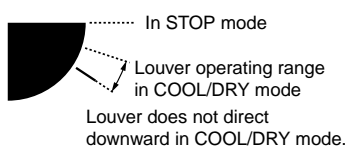

To automatically swing the air flow direction

Perform this function when the air conditioner is operating.

1 SWING button

Push the SWING button on the remote controller.

- To stop the function, push the SWING button.
- To change the swinging direction, push the FIX button.

- In COOL/DRY operation, the louver does not stop as it directs downward. If stopping the louver as it directs downward during swing operation, it stops after moving for a small duration.

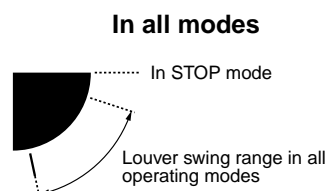

CAUTION

- The FIX and SWING buttons will be disabled when the air conditioner is not operating (including when the ON TIMER is set).
- Do not operate the air conditioner for an extended period of time with the air flow direction set downward during the cooling or drying operation: otherwise condensation may occur on the surface of the air flow louver and cause water dripping.
- Do not move the air flow louver manually. Always use the FIX button. If you move the louver manually, it may malfunction during operation. If the louver malfunctions, stop the air conditioner, and restart it.
- When the air conditioner is started immediately after it was stopped, the air flow louver may not move for about 10 seconds.

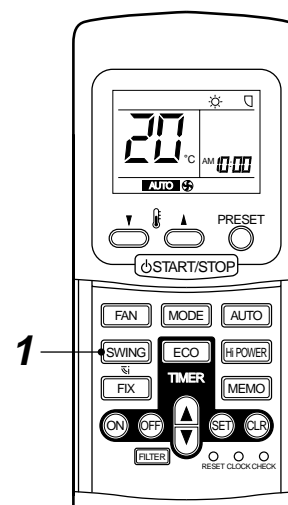

HOW THE AIR CONDITIONER WORKS

Automatic Operation

As shown in Figures 1 and 2, Automatic Operation mode selects the operation based on the room temperature data (Ta) when operation begins.

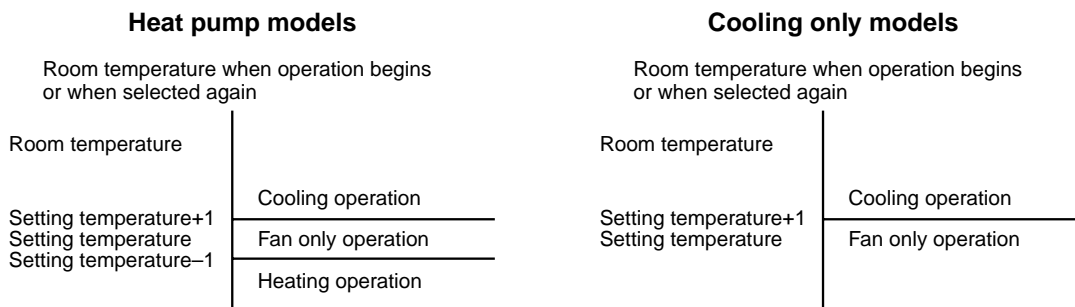

Figure 1

Figure 2

The operation mode is selected again after the compressor has remained stopped for 15 minutes.

Hi POWER operation

When you push the Hi POWER button during cooling, heating or A operation, the air conditioner starts the following operation.

- **Cooling operation**

The cooling operation is performed at 1°C lower than the temperature setting.

When the room temperature is higher than the temperature setting, the air flow is directed downward.

The fan speed is also set to high*.

Once the room temperature is within 1°C of the set temperature, the air flow is returned to its previous direction.

* The noise level increases, according to the fan speed.

- **Heating operation (heat pump models)**

The heating operation is performed at 2°C higher than the set temperature.

The air flow direction and fan speed are automatically switched according to the operating condition.

ECO operation

When you push the ECO button during cooling, heating or A operation, the air conditioner starts the following operation. The fan speed is controlled automatically.

- **Cooling operation (⚙)**

In the minimum operation zone, where the air conditioner is operated at minimum capacity, overcooling is prevented by raising the set temperature.

The room temperature is thus regulated between the minimum operation zone and the set temperature.

- **Heating operation (⚙) (heat pump models)**

In the minimum operation zone, where the air conditioner is operated at minimum capacity, overheating is prevented by lowering of the set temperature.

The room temperature is thus regulated between the set temperature and the minimum operation zone.

Dry operation (☁)

The dry mode automatically selects the cooling dry operation based on the difference between the set temperature and the actual room temperature.

The fan speed indicator shows AUTO and low speed is used.

HINTS FOR ECONOMICAL OPERATION

Maintain room temperature at a comfortable level

Clean air filters

The clogged/dirty air filter impairs the performance of the air conditioner.

Never open doors and windows more often than necessary

To keep cool or warm air in the room, never open doors and windows more often than necessary.

Window curtains

In cooling, close the curtains to avoid direct sunlight.

In heating, close the curtains to keep the heat in.

Get uniform circulation of room air

Adjust the air flow direction for the even circulation of room air.

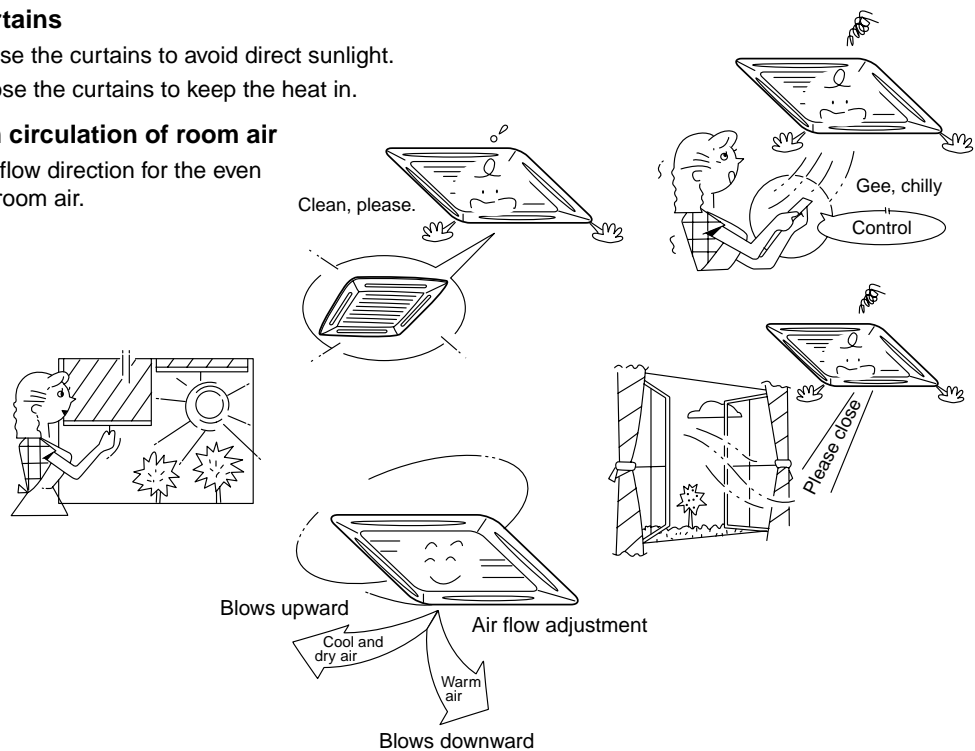

TEMPORARY OPERATION

This function is used to operate the unit temporarily in case you take a remote controller for the right one or the batteries are fully discharged.

- Push the RESET button to start the automatic operation (AUTO).
- While the temporary operation is activated, the remote controller operation is disabled.

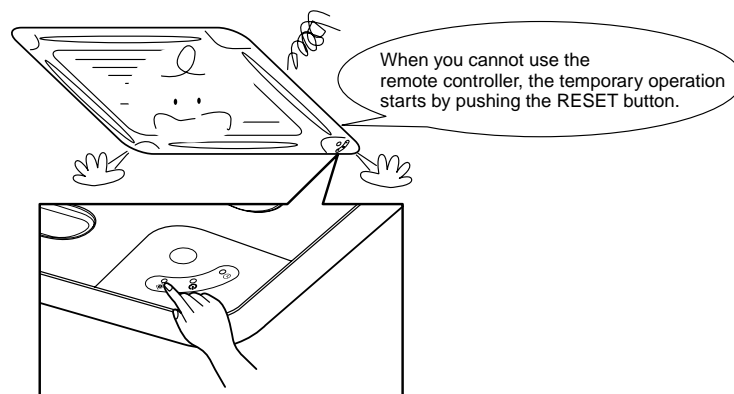

MAINTENANCE

Cleaning of the air filter

⚠ WARNING

Cleaning of the air filter and other parts of the air filter can involve dangerous work in high places, therefore ensure work is carried out by qualified service personnel.

Do not attempt it yourself.

NOTE

For Air conditioning systems which are operated regularly, cleaning and maintenance of the indoor/outdoor units are strongly recommended.

As a general rule, if an indoor unit is operated for about 8 hours a day, the indoor/outdoor units will need to be cleaned at least once every 3 months.

Cleaning and maintenance shall be carried out by a qualified person.

Failure to clean the indoor/outdoor units regularly will result in poor performance, icing, water leaking or even compressor failure.

Cleaning of the remote controller

CAUTION

- Use a dry cloth to wipe the remote controller.
- A cloth dampened with cold water may be used on the indoor unit if it is very dirty.
- Never use a damp cloth on the remote controller.
- Do not use a chemically-treated duster for cleaning nor leave such materials on the unit for long.
It may damage or fade the surface of the unit.
- Do not use benzene, thinner, polishing powder or similar solvents for cleaning. These may cause the plastic surface to crack or deform.

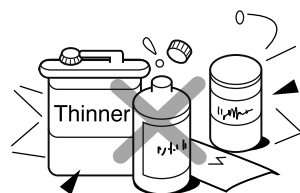

If you do not plan to use the unit for more than 1 month

- 1) Operate the fan for 3 to 4 hours to dry inside of the unit
 - Operate "FAN" mode.
- 2) Stop the air conditioner and turn off the main power switch or the circuit breaker.



FAN operation

Checks before operation

- 1) Check that the air filters are installed.
- 2) Check that the air outlet or inlet is not blocked.
- 3) Turn on the main power switch or the circuit breaker for the main power supply to the air conditioner.

AIR CONDITIONER OPERATION AND PERFORMANCE

3 minutes protection function

The outdoor unit will not operate for approximately 3 minutes after the air conditioner has been immediately restarted after being stop, or the power supply has been turned on. This is to protect the system.

Power failure

Power failure during operation stops the unit completely.

- To restart the operation, push the START/STOP button on the remote controller.
- Lightning or a wireless mobile telephone operating nearby may cause the unit to malfunction.
Turn off the main power switch or circuit breaker and then turn them on again.
Push the START/STOP button on the remote controller to restart.

Heating characteristics

Preheating operation

The air conditioner does not flow out warm air immediately after it is turned on.

Warm air starts to flow out approximately 5 minutes after the indoor unit heat exchanger warmed up.

Warm air control (In heating operation)

When the room temperature reaches the set temperature, the fan speed is automatically reduced or stop to prevent blowing cold draft.

At this time, the outdoor unit stops.

Defrosting operation

If the outdoor unit frosts during the heating operation, defrosting starts automatically (for approximately 2 to 10 minutes) in order to maintain the heating capacity.

- The fans in both indoor and outdoor units stops during the defrosting operation.
- During the defrosting operation, the defrosted water drains into the bottom plate of the outdoor unit.

Heating capacity

In the heating operation, the heat is absorbed from the outside and brought into the room.

This way of heating is called heat pump system.

When the outside temperature is too low, it is recommended using another heating apparatus in combination with the air conditioner.

Attention to snowfall and freeze on the outdoor unit

- In snowy areas, the air inlet and air outlet of the outdoor unit are often or covered frozen up with snow.
If snow or the outdoor unit is frozen and is left as it is, it may cause machine failure or poor heating.
- In cold areas, pay attention to the drain hose so that it perfectly drains water without remaining any water inside.
If water freezes in the drain hose or inside the outdoor unit, it may cause machine failure or poor heating.

RE-INSTALLATION

⚠ DANGER

Ask the dealer or an installation professional to re-install the air conditioner in a new location and to observe the following items.

If the air conditioner is incorrectly installed yourself, it may cause a risk of an electric shock or a fire.

Do not install the air conditioner in the following places

- Do not install the air conditioner in any place within one meter from a TV, stereo, or radio set. If the unit is installed in such a place, noise transmitted from the air conditioner may affect the operation of these appliances.
- Do not install the air conditioner near to a high frequency appliance (sewing machine or massager for business use, etc.), otherwise the air conditioner may malfunction.
- Do not install the air conditioner in a humid or oily place, or in a place where steam, soot, or corrosive gases are generated.
- Do not install the air conditioner in a salty place such as a seaside area.
- Do not install the air conditioner in a place where large amounts of machine oil are used.
- Do not install the air conditioner in a place where it is usually exposed to strong winds, such as in a sea-side area or on the roof of the upper floor of a building.
- Do not install the air conditioner in a place where sulfurous gases are generated, such as in a spa.
- Do not install the air conditioner in a vessel or a mobile crane.

Be careful with noise or vibrations

- Do not install the air conditioner in a place where noise or hot air from the outdoor units air outlets may annoy neighbors.
- Install the air conditioner on a solid and stable foundation so that it prevents the transmission of resonating, operation noise and vibration.
- If one indoor unit is operating, some sound may be audible from other indoor units that are not operating.



TROUBLES AND CAUSES

CAUTION

If any of the following conditions occur, turn off the main power supply switch and immediately contact your dealer :

- The operation lamps flash at short intervals (5 times per second) even though you have tried turning off the power supply and turning on again after 2 or 3 minutes.
- Switch operation does not work correctly.
- The main power fuse often blows out, or the circuit breaker is often activated.
- A foreign matter or water inside of the air conditioner.
- Any other unusual conditions are observed.

Before you ask for servicing or repairs, check the following points.

Recheck

Inoperative

- The main power switch is turned off.
- The circuit breaker is activated to cut off power supply.
- The main power fuse has blown.
- No electrical current

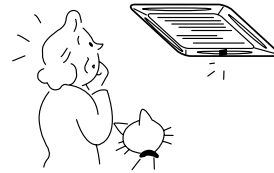

Does not cool well or heat well

- The air inlet and/or outlet of the outdoor unit is blocked.
- Doors or windows are opened.
- The fan speed is set to low.
- The air conditioner is set in the DRY mode.
- The set temperature is too high. (In cooling operation)
- The set temperature is too low. (In heating operation)

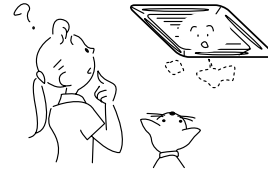

Indoor unit or outdoor unit makes a strange noise.

- When the temperature suddenly changes, the indoor or outdoor unit occasionally makes a strange noise because of expansion/contraction of parts or change of refrigerant flow.

The room air is smelly or a bad odor comes from the air conditioner.

- Smells impregnated in the walls, carpets, furniture, clothing, or furs, come out.

Outdoor unit is frosted in heating operation.

Water drains from the outdoor unit.

- The outdoor unit is sometimes frosted in heating operation. In such case, the unit automatically performs defrosting (for 2 to 10 minutes) for increasing of the heating efficiency.
- In defrosting operation, both the indoor and outdoor units stop air flow.
- A hiss sound is heard when flow of the refrigerant is changed for defrosting.
- Resultant water of automatic defrosting in heating operation drains from outdoor unit.

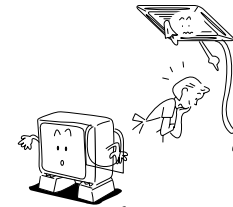

These are not failures.

Air flow changes though the FAN button is not set to the AUTO mode.

- When the temperature of the blown air drops in heating operation, the air conditioner automatically changes or stops air flow from the indoor unit not to prevent the person in the room feeling cold.
- Air flow from the indoor unit is occasionally changed in the cooling operation.



A white mist of chilled air or water is generated from the outdoor unit.

- The indoor unit in cooling operation or the outdoor unit in defrosting operation occasionally gives off steam.



The OPERATION indicator turns on and off.

- The indicator turns on and off (once per 1 second) when power is restored after a power failure or when the power main switch is set to on. If you use the remote controller for ON → OFF operation, the indicator does not flash.



Automatic operation of air flow louvers

- When the room temperature or outdoor temperature is high during the heating operation, the vertical air flow louvers close once and then set themselves automatically to the original position setting again.



Cool, Dry, or Heat operation cannot be performed.

- When the unit in other room operates previously in different mode, Fan-only operation is performed because of first-push priority control. (Cool operation and Dry operation can be concurrently performed.)

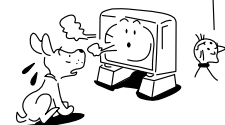

TROUBLE AND CAUSES (Concerning Remote Controller)

Before you ask for servicing or repair work, check the following points:

Setting Change is Impossible		
Symptoms	Causes	Reason and Disposal
The fan speed can not be changed.	<ul style="list-style-type: none"> Check whether the MODE indicated on the display is "AUTO". <p style="text-align: center;">AUTO</p>	When the automatic mode is selected, the air conditioner automatically selects the fan speed.
	<ul style="list-style-type: none"> Check whether the MODE indicated on the display is "DRY". <p style="text-align: center;"> (DRY)</p>	When dry operation is selected, the air conditioner automatically selects the fan speed.

The Transmission Indicator "▲" Never Goes On		
Symptoms	Causes	Reason and Disposal
The remote controller signal is not transmitted even when the ECONO. FAN button is pushed.	<ul style="list-style-type: none"> Check whether the ON TIMER is indicated on the display. 	The remote controller signal is not transmitted, because the air conditioner is off.

The Display Never Goes On		
Symptoms	Causes	Reasons
The TEMP. indicator does not go on. (for cooling only model)	<ul style="list-style-type: none"> Check whether the MODE indicated on the display is "FAN ONLY". <p style="text-align: center;"> (FAN ONLY)</p>	The temperature can not be set during fan only operation.

The Display Goes Off		
Symptoms	Causes	Reasons
The indication on the display disappears after a lapse of time.	<ul style="list-style-type: none"> Check whether the timer operation has come to an end when the OFF TIMER is indicated on the display. 	The air conditioner operation stops as the set time has elapsed.
The TIMER indicators go off after a certain time has elapsed.	<ul style="list-style-type: none"> Check whether the timer operation has started when the ON TIMER is indicated on the display. 	When the time set to start the air conditioner has been reached, the air conditioner will automatically start and the appropriate indicator will go off.

The Signal Receiving Tone Does Not Sound		
Symptoms	Causes	Disposal
No receiving tone sounds from the indoor unit even when the START/STOP button is pushed.	<ul style="list-style-type: none"> Check whether the signal transmitter of the remote controller is properly directed at the receiver of the indoor unit when the START/STOP button is pushed. 	Direct the signal transmitter of the remote controller to the receiver of the indoor unit and then repeatedly push the START/STOP button twice.